

# ALPS CAPTO

ALPS CAPTO tooling

## ALPS CAPTO Adapter Catalog

The most suitable coupling for  
multi task machine (MTM), CNC lathes, and machining center.

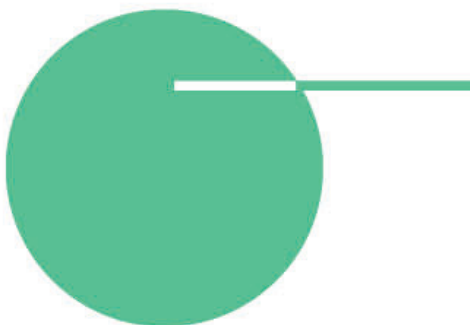

● Improve productivity by reducing setup time!

## The Ideal 2-sided restraint coupling.

- High rigidity
- High Accuracy
- Quick change system
- Tool sharing between lathes and machining center.

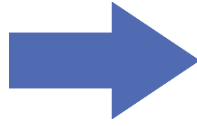

**COST REDUCTION**  
**HIGHER PRODUCTIVITY**

ALPS CAPTO is 2-sided restraint coupling consisting of a polygonal 1/20 taper and end face.

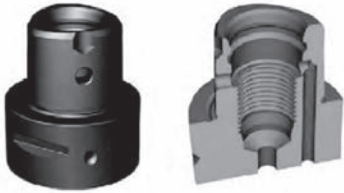

**2-sided restraint coupling** : Increases bending rigidity.

**Keyless coupling** : Increases rigidity and durability by receiving torque evenly on three surfaces.  
Eliminates errors caused by keys and improves accuracy.

**High quality coupling** : Repeatability  $\pm 2 \mu\text{m}$ , minimum runout.

ALPS CAPTO's high rigidity and accuracy make it suitable for all types of machining, including turning, milling, and drilling.

### Size



ALPS CAPTO is available in 5 sizes from C3 to C8.

- C3 D=32mm : 20 Square Shank
- C4 D=40mm : 25 Square Shank
- C5 D=50mm : 32 Square Shank/BT40
- C6 D=63mm : 40 Square Shank/BT45
- C8 D=80mm : 50 Square Shank/BT50

Clamp unit clamps polygon formed tapered shank with several tons of pressure.

ALPS CAPTO demonstrates its maximum rigidity against bending and twisting.

Gapless polygon form realizes the smallest runout.

Error in height of the blade edge is eliminated owing to coupling without drive key.

**Finishing** : Stabilizing the machining dimensions of the workpiece.

**Roughing** : Preventing cutting edge movement and damage caused by large cutting loads.

self-centering

Large contact surface

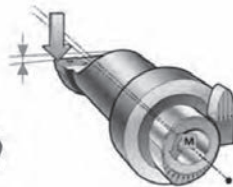
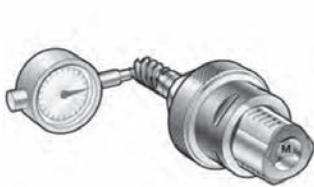
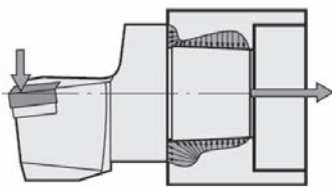
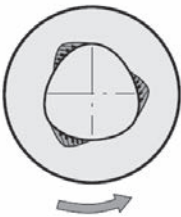

### Repeatability

X axis  
Y axis  
Z axis  
Each has repeatability of  $\pm 2\mu\text{m}$ .



Quick change system

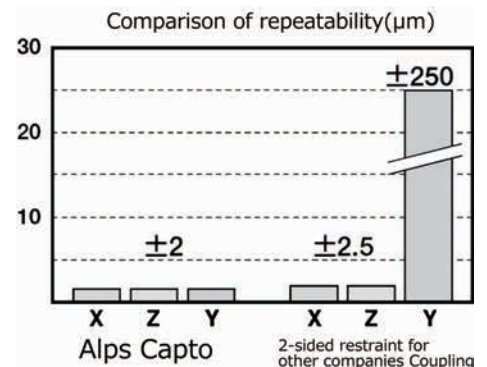
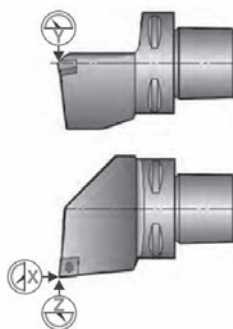

## High rigidity

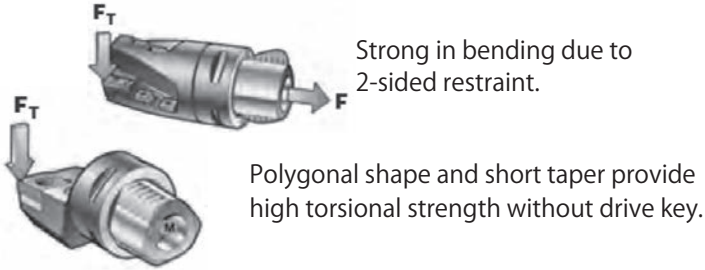

Turning: Comparison of maximum cutting depth (mm).

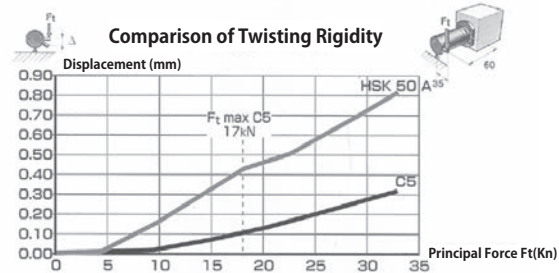
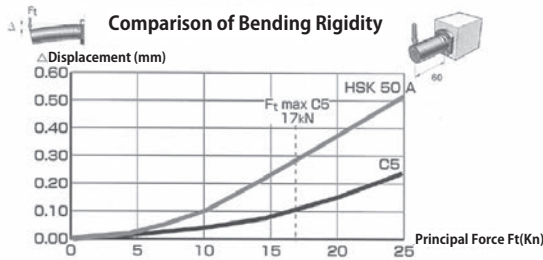
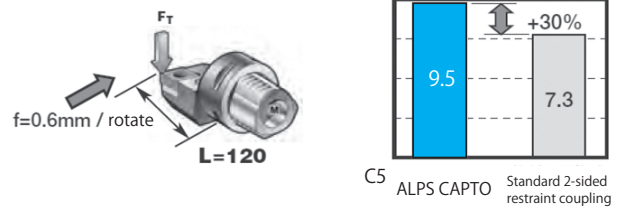

## Quick change to reduce machine downtime.

Tool setup time. / 8.5 min.

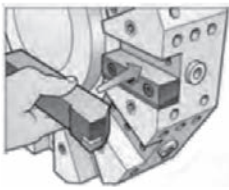

Tool setup time. / 8.5 min.

Cutting edge change time. / 2.5 min.

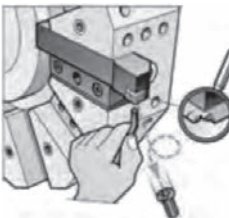

ALPS CAPTO / 1 min.

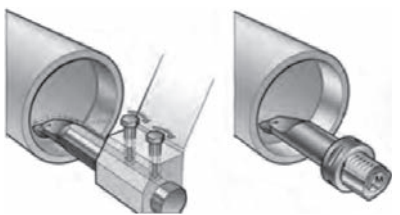
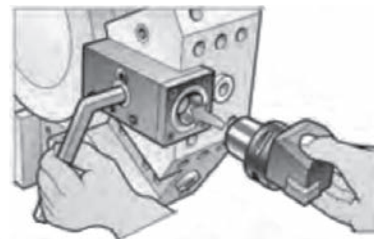

Direct clamping prevents vibration.

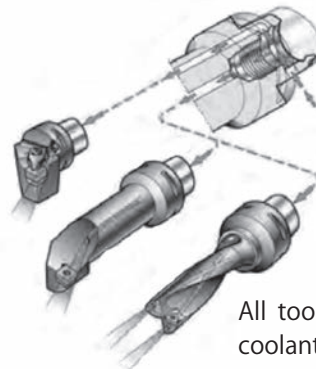

All tools have internal coolant supply.



Tool ID support.

## Modular tooling for tool consolidation and standardization.



**Integrated Tooling**



Efficient tool utilization.

Tool length can be set with standard tools by recombination.



## Quick change tooling system for CNC lathes

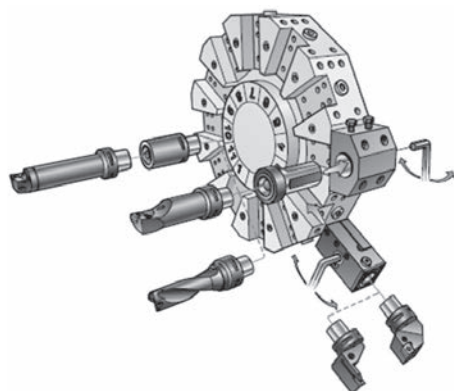

### Direct mount type

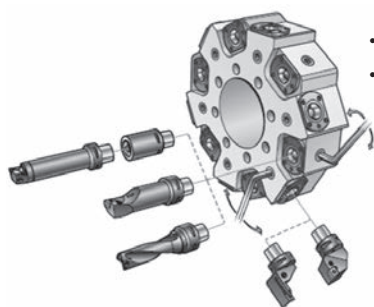

- Increases rigidity.
- Simple and compact (No clamp holder required)

### General turret

#### Square shank clamping unit



Cam type

h SIZE	Capto SIZE
40	C3
50	C4
64	C5

#### Round shank clamping unit

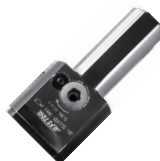

Cam type

dm SIZE	Capto SIZE
32	C3
40	C4



Pull-screw type

dm SIZE	Capto SIZE
32	C3
40	C4
50	C5

## Quick change tooling system for turning centers.

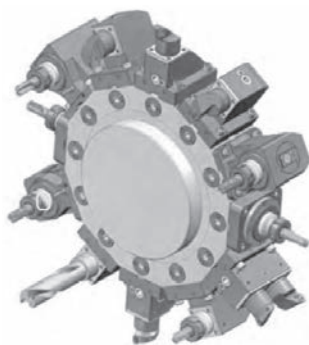
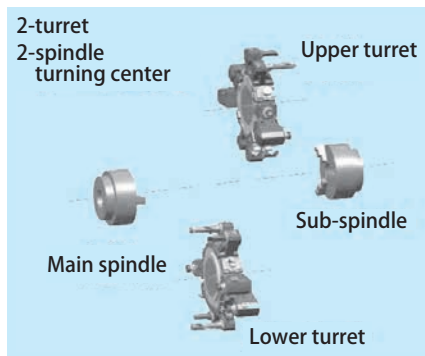

### CDI type quick change

- Space-saving
- Static/ Live tools
- Common interface
- Shorter holder than VDI
- Increases rigidity / Increases processing range
- Quick change by ALPS CAPTO

### Static Tool Holder

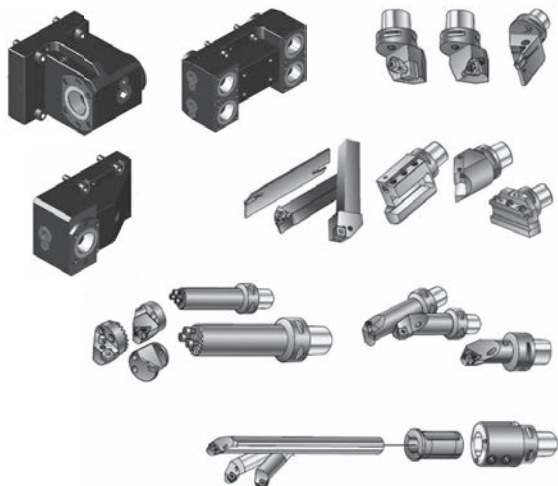

### Live Tool Holder

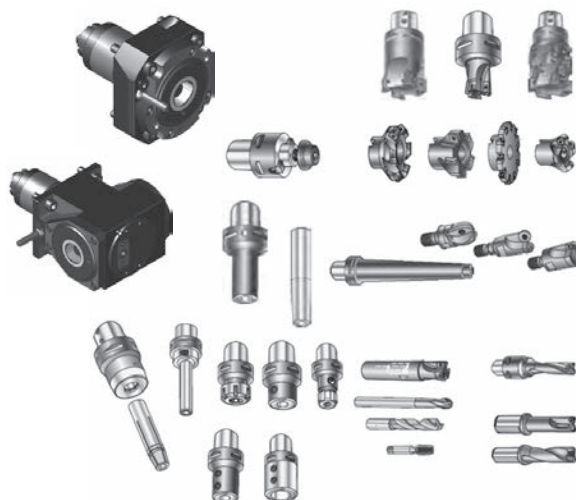

## Clamping Mechanism

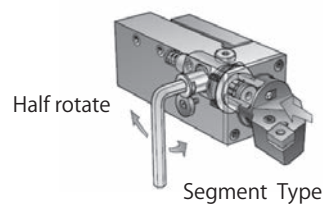
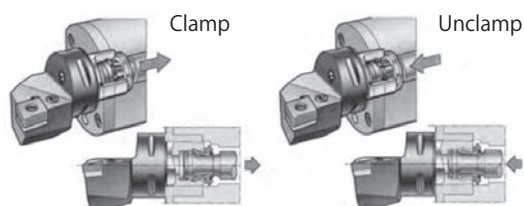

Capto clamp system clamps/ unclamps tooling with the movement of the draw bar and the segment.

## Quick Change

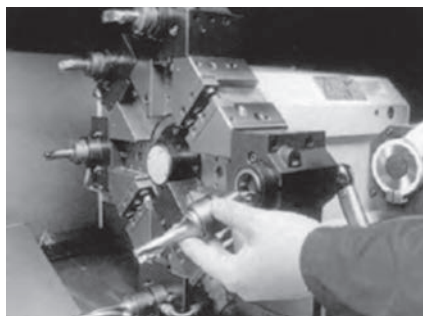

Compared to an average on-site tool change time of 8.5 minutes and cutting edge change time of 2.5 minutes, ALPS CAPTO's quick change takes an average of 1 minute. This significantly reduces machine downtime. Generally, a combination of one or two clamping units and four to ten cutting units can save 50 to 200 hours/year. By using this reduced time for machining, productivity can be improved by about 25% and machining costs can be reduced.

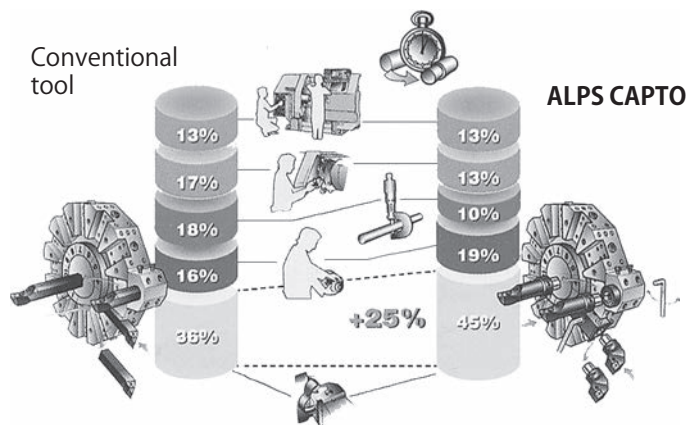

**Quick change significantly reduces a machine stopping time for tool changing and contributes to cost reduction.**

Tool setup time. / 8.5 min.

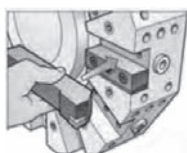

ALPS CAPTO / 1 min.

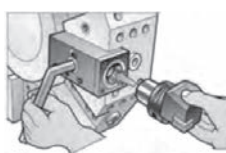

**Repeatability of  $\pm 2\mu\text{m}$**

No need to change tools as the same clamping unit is used.

Holder change time time reduction	Number of holder changes/shift	Shift	Holder replacement time time reduction/day	Working days	Holder replacement time/year
<b>7.5min</b>	<b>1</b>	<b>1</b>	<b>= 7.5min</b>	<b>225</b>	<b>= 1687min = 28h</b>
		<b>2</b>	<b>= 15min</b>		<b>= 3375min = 56h</b>
<input type="text"/>	<input type="text"/>	<input type="text"/>	<input type="text"/>	<input type="text"/>	<input type="text"/> /60 = <input type="text"/>

Cutting edge change time. / 2.5 min.

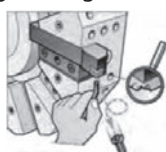

ALPS CAPTO / 1 min.

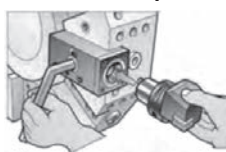

**Repeatability of  $\pm 2\mu\text{m}$**

No need to change tools as the same clamping unit is used.

Tip change time time reduction	Tip of holder changes/shift	Shift	Tip replacement time time reduction/day	Working days	Tip replacement time/year
<b>1.5min</b>	<b>5</b>	<b>1</b>	<b>= 7.5min</b>	<b>225</b>	<b>= 1687min = 28h</b>
		<b>2</b>	<b>= 15min</b>		<b>= 3375min = 56h</b>
<input type="text"/>	<input type="text"/>	<input type="text"/>	<input type="text"/>	<input type="text"/>	<input type="text"/> /60 = <input type="text"/>

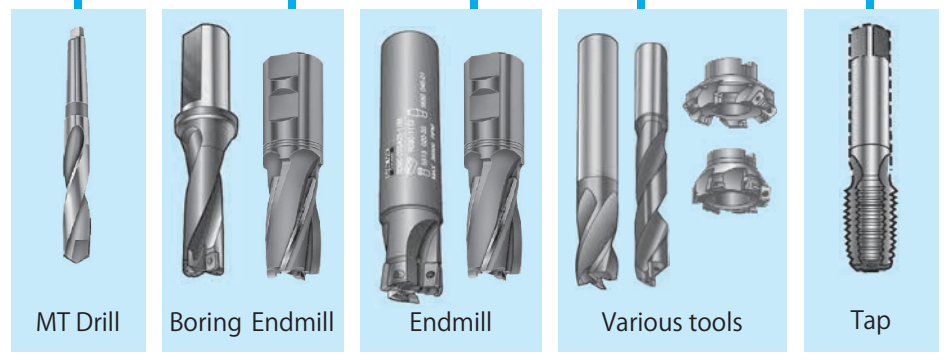
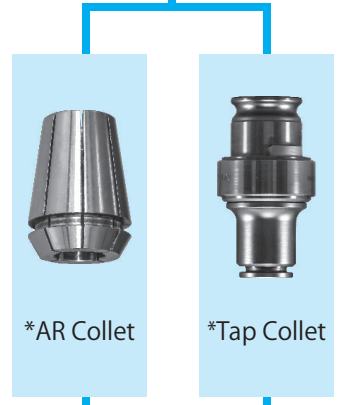
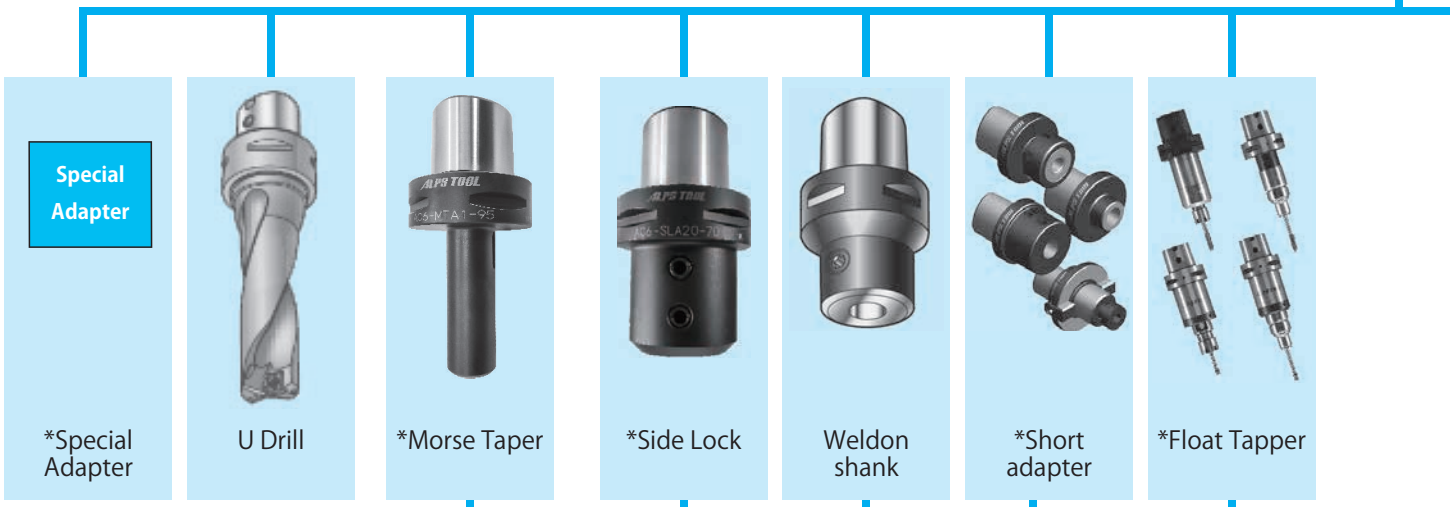
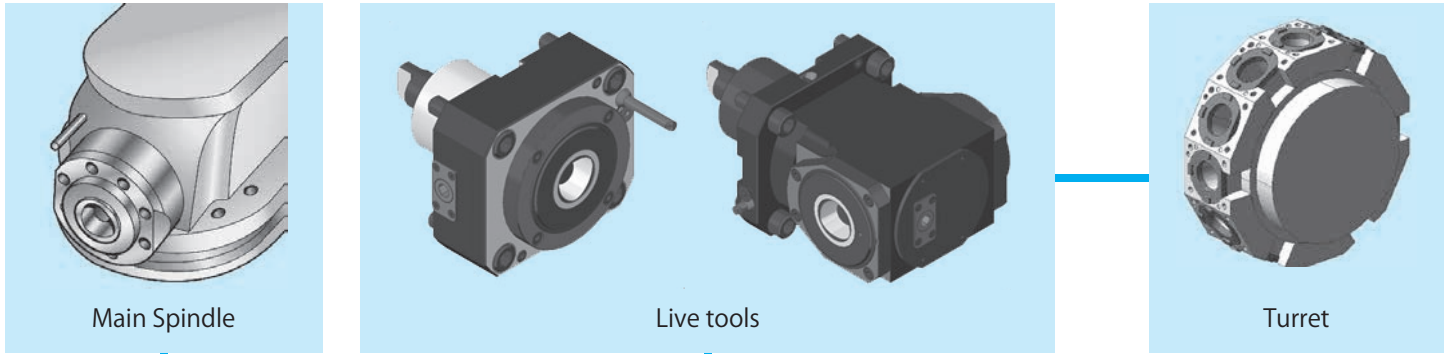

**\*Marked products are made by Alpstool**

\*For items not marked, please select from the Sandvik catalogue.

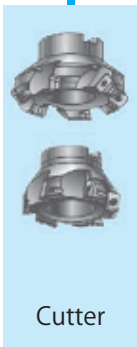
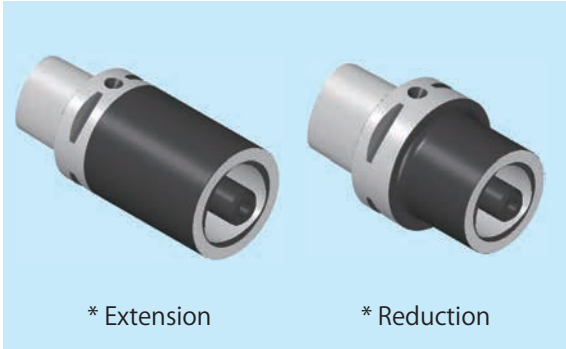



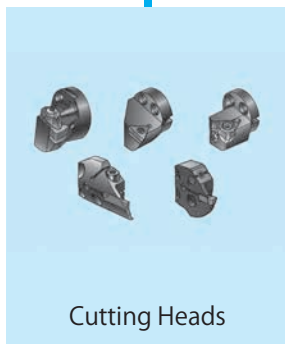
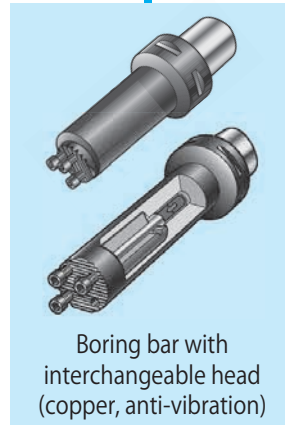
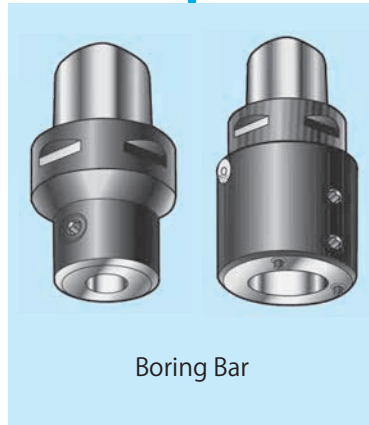
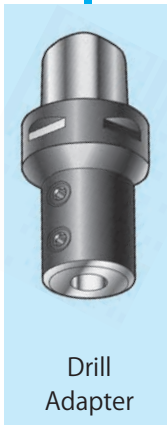
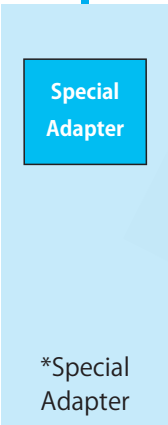
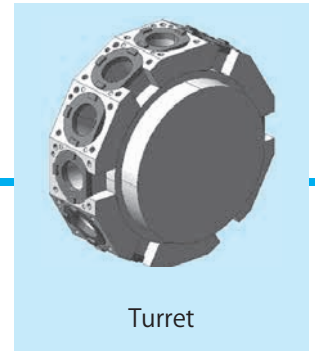
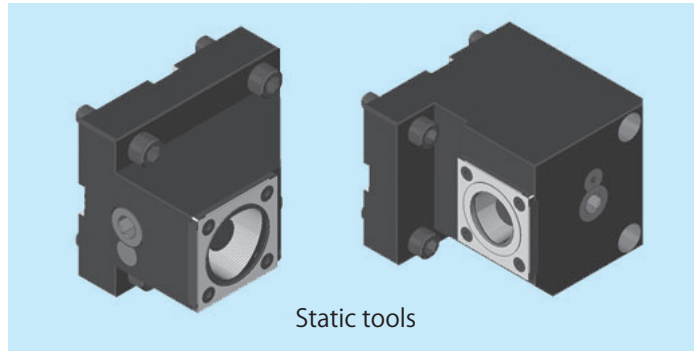
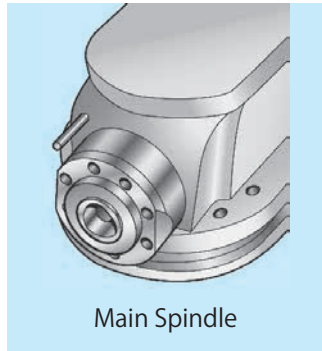

**\*Marked products are made by Alpstool**

\*For items not marked, please select from the Sandvik catalogue.



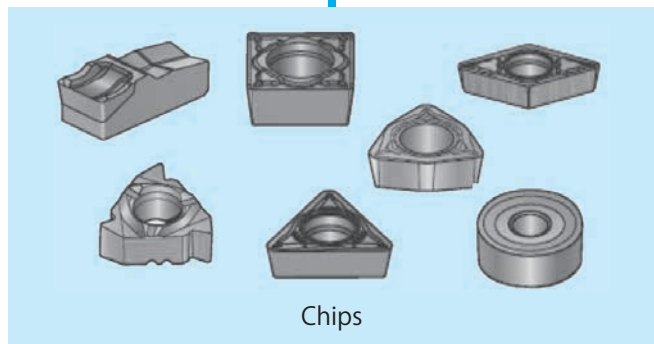
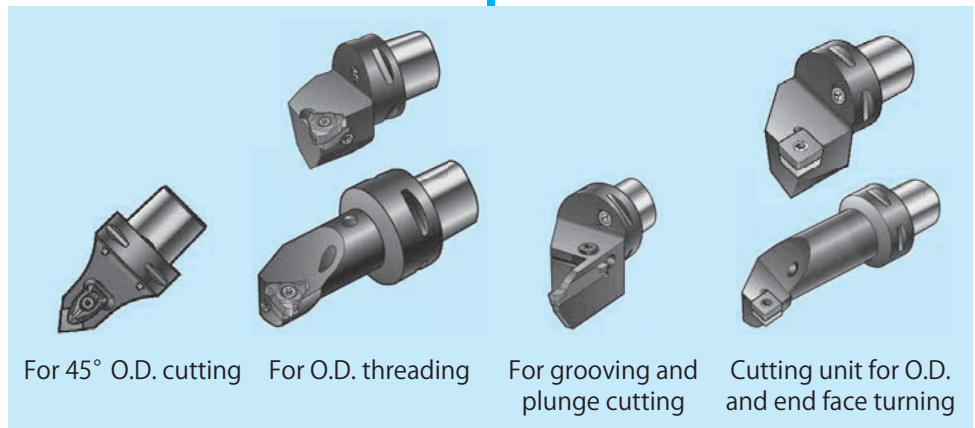

## Slim, High Balance, Excellent versatility

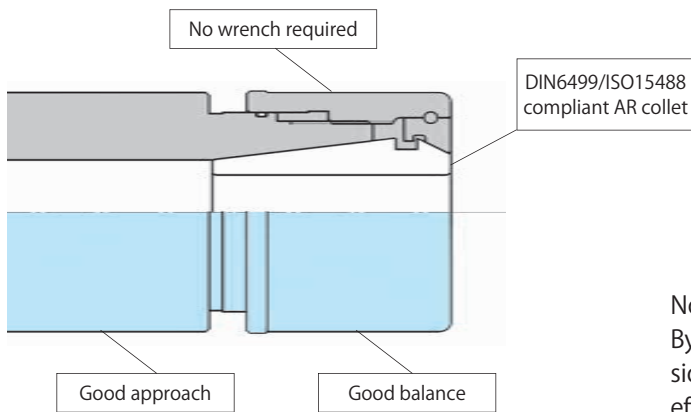

## Compatible with various coolant methods



Center Thru

Side Thru

No special nuts or seals required!

By simply replacing the collet, it supports center through coolant / side through coolant. Compatible with high pressure of 7MPa, it is effective for cooling the cutting edge and removing chips.

## By simply replacing the collet, it supports various functions such as coolant through, tapping, etc.

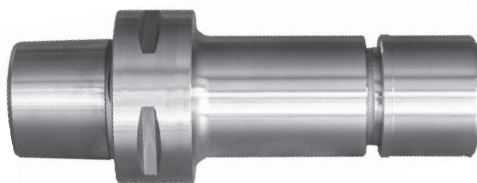

Collet replacement allows for immediate use in a variety of applications

## Reliable high-precision collets.

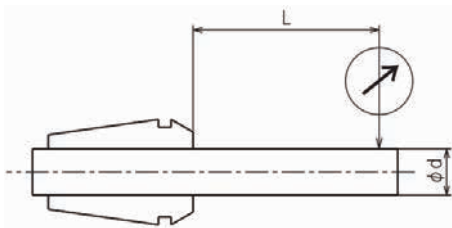

AR chuck collets are 16 ° taper collets that comply with DIN6499/ISO15488 and are highly available.

Under the ISO9001 quality system, collets with stable quality are provided.

The AR series is available in standard, center-through, side-through, taps and coolant taps to suit a variety of applications.

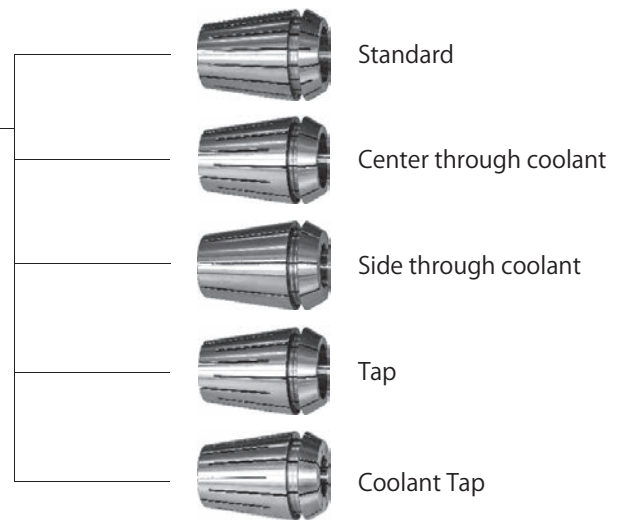

Nominal Diameter D1	L	Accuracy by grade ( μ m)		
		AAA	AA	A
1~1.5	4 × D1	*3 μ	*5 μ	8 μ
2~5.5	4 × D1		5 μ	
6~10	25			
11~26	40			

Runout accuracy marked with an \* is made to order.

## Easy setup with simple and reliable tool change.

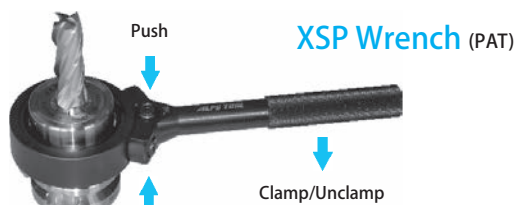

Easy to attach and detach by simply switching with the push button and turning.

The XSP wrench, which uses a clutch, can apply uniform force to the entire circumference of the nut, allowing it to tighten the nut safely and reliably. The XSP wrench can switch the direction of rotation with the push button, making it easy to operate when changing tools.

## Compatible with irregularly shaped tools.

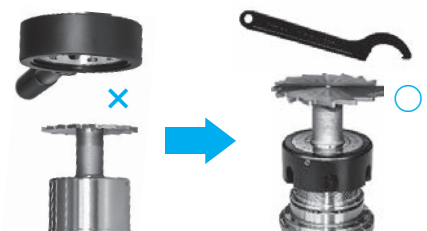

By replacing the nut, it can also be used with large diameter cutters.

The EXH holder can be replaced with a nut (NA-F), and umbrella-shaped tools can also be used safely.

# EXH type Collet Holder

Suitable for drills, end mills, taps, and reamers.

- ◆ Slim and low interference shape.
- ◆ High pressure 7MPa coolant through.

**Coolant Thru**

Center Thru / Side Thru Available

● Form explanation

AC5- EXH 10- 105

- L Dimension
- Max Grasp Diameter
- Holder Type
- Shank Type

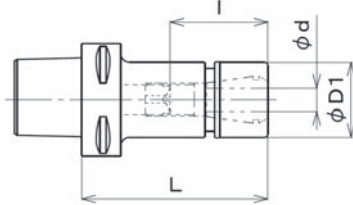

Center Thru



Side Thru

SIZE	CODE	Collet Chuck Code		Dimension				Adjust Bolt		Nut	Wrench	
				φ d	φ D1	L	l	w/o Hole	w/ Hole			
C5	AC5- EXH 7 - 60	AR11-d	AR110H-d	0.5-7	23	60	42.5 ※	ECH7-05	ECH70H-05	NA11FX	XSP23	
	- 90					20~45						
	-105											
	-120											
	-120											
	AC5- EXH10 - 60	AR16-d	AR160H-d	0.5-10	30	60	42 ※	ECH10-05	ECH100H-05	NA16FX	XSP30	
	- 90					30~50						
	-105											
	-120											
	-135											
	AC5- EXH13 - 60	AR20-d	AR200H-d	0.5-13	35	60	45 ※	ECH13-05	ECH130H-05	NA20FX	XSP35	
	- 90					35~55						
	-105											
	-120											
	-135											
	AC5- EXH16 - 60	AR25-d	AR250H-d	0.5-16	42	60	52 ※	ECH16-05	ECH160H-05	NA25FX	XSP42	
	- 75					40~55						
	- 90											
-105												
-120												
-135	40~65											
AC5- EXH20 - 60		AR32-d	AR320H-d	2.5-20	50	60	52 ※	ECH20-05	ECH200H-05	NA32FX	XSP50	
- 75						45~51						
- 90												
-105												
-120												
-135	45~60											
-135		45~65										
AC6- EXH 7 - 60			AR11-d	AR110H-d	0.5-7	23	60	38.5 ※	ECH7-05	ECH70H-05	NA11FX	XSP23
- 75							20~35					
- 90												
-105												
-120												
-135												
-165												
AC6- EXH10 - 60	AR16-d	AR160H-d	0.5-10	30	60	41 ※	ECH10-05	ECH100H-05	NA16FX	XSP30		
- 75					30~50							
- 90												
-105												
-120												
-135												
-165						30~55						
-200												

# EXH type Collet Holder

SIZE	CODE	Collet Chuck Code		Dimension				Adjust Bolt		Nut	Wrench
				$\phi$ d	$\phi$ D1	L	l	w/o Hole	w/ Hole		
C6	AC6- EXH13 - 60	AR20-d	AR20OH-d	0.5-13	35	60	41 ※	ECH13-05	ECH13OH-05	NA20FX	XSP35
	- 75					75	52 ※				
	- 90					90	35~45				
	-105					105	35~55				
	-120					120					
	-135					135					
	-165					165	35~65				
	-200					200					
	AC6- EXH16 - 60					AR25-d	AR25OH-d				
	- 75	75	51 ※								
	- 90	90	40~49								
	-105	105	40~55								
	-120	120									
	-135	135									
	-165	165	40~65								
	-200	200									
	AC6- EXH20 - 60	AR32-d	AR32OH-d	2.5-20	50	60	50 ※	ECH20-05	ECH20OH-05	NA32FX	XSP50
	- 75					75	65.5 ※				
- 90	90					64 ※					
-105	105					45~55					
-120	120					45~60					
-135	135										
-165	165					45~65					
-200	200										
C8	AC8- EXH10 - 70	AR16-d	AR16OH-d	0.5-10	30	70	56.5 ※	ECH10-05	ECH10OH-05	NA16FX	XSP30
	- 90					90					
	-105					105	30~50				
	-120					120					
	-135					135					
	-165					165	30~55				
	AC8- EXH13 - 70	AR20-d	AR20OH-d	0.5-13	35	70	55 ※	ECH13-05	ECH13OH-05	NA20FX	XSP35
	- 90					90					
	-105					105	35~55				
	-120					120					
	-135					135					
	-165					165	35~65				
	-200	200									
	AC8- EXH16 - 70	AR25-d	AR25OH-d	0.5-16	42	70	54 ※	ECH16-05	ECH16OH-05	NA25FX	XSP42
	- 90					90	40~53				
	-105					105	40~55				
	-120					120					
	-135					135	40~65				
-165	165										
-200	200										
AC8- EXH20 - 70	AR32-d	AR32OH-d	2.5-20	50	70	53 ※	ECH20-05	ECH20OH-05	NA32FX	XSP50	
- 90					90	73 ※					
-105					105	45~60					
-120					120						
-135					135						
-165					165	45~65					
-200					200						

- ◆ NOTES ◆
- Slit through coolant becomes available by using AR collet (AR □□ -D)
  - Center through coolant becomes available by using AR coolant collet (AR □□ OH-D)
  - Please order a wrench separately.
  - When using an umbrella-shaped tool, replace the standard nut with the NA □□ F type
  - Adjust bolt cannot be used with ※ marked items.

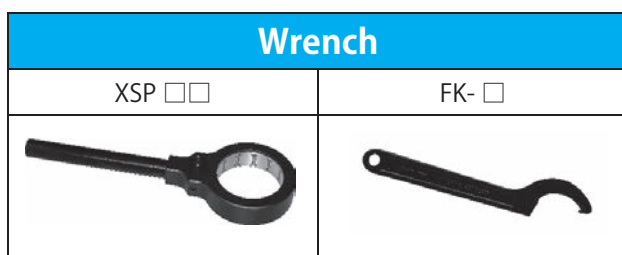

Holder Type	Standard Nut	Wrench	Nut for T-Cutter	Wrench for T-Cutter Nut
ECH 7	NA11FX	XSP23	NA11F	FK-3
ECH10	NA16FX	XSP30	NA16F	FK-4
ECH13	NA20FX	XSP35	NA20F	FK-5
ECH16	NA25FX	XSP42	NA25F	FK-6
ECH20	NA32FX	XSP50	NA32F	FK-7



# ECH type Collet Holder

Suitable for drills, end mills, reamers, and small diameter boring.

**Coolant Thru**

◆ 7MPa Coolant Thru Available

● Form explanation

Center Thru / Side Thru Available

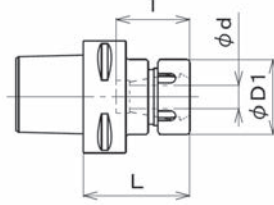

AC5 - ECH 10 F - 105

L Dimension  
Tip Shape  
Max Grasp Diameter  
Holder Type  
Shank Type



Center Thru



Side Thru

SIZE	CODE	Collet Chuck Code		Dimension				Adjust Bolt		Nut	Wrench
				φ d	φ D1	L	l	w/o Hole	w/ Hole		
C3	AC3- ECH10F - 35	AR16-d	AR16OH-d	1-10	30	35	33			NA16F	FK-4
	ECH13F - 43	AR20-d	AR20OH-d	1-13	35	43	37			NA20F	FK-5
C4	AC4- ECH13F - 45	AR20-d	AR20OH-d	1-13	35	45	37	-	-	NA20F	FK-5
	ECH16F - 50	AR25-d	AR25OH-d	1-16	42	50	41.5			NA25F	FK-6
	ECH20F - 55	AR32-d	AR32OH-d	3-20	50	55	47.5			NA32F	FK-7
C5	AC5- ECH 7F - 60	AR11-d	AR11OH-d	0.5-7	23	60	22.5	ECH7-05	ECH7OH-05	NA11F	FK-3
	- 90										
	ECH10F - 60	AR16-d	AR16OH-d	1-10	30	60	33	-	-	NA16F	FK-4
	- 90					ECH10-05		ECH10OH-05			
	ECH13F - 60	AR20-d	AR20OH-d	1-13	35	60	37	-	-	NA20F	FK-5
	- 90					ECH13-05		ECH13OH-05			
	ECH16F - 60	AR25-d	AR25OH-d	1-16	42	60	41.5	-	-	NA25F	FK-6
	- 90					ECH16-05		ECH16OH-05			
ECH20F - 60	AR32-d	AR32OH-d	3-20	50	60	47.5	-	-	NA32F	FK-7	
- 90					ECH20-05		ECH20OH-05				
ECH26F - 70	AR40-d	AR40OH-d	3-26	61.5	70	54.5	-	-	NA40F	FK-9	
C6	AC6- ECH 7F - 60	AR11-d	AR11OH-d	0.5-7	23	60	22.5	ECH7-05	ECH7OH-05	NA11F	FK-3
	- 90										
	ECH10F - 60	AR16-d	AR16OH-d	1-10	30	60	33	-	-	NA16F	FK-4
	- 90					ECH10-05		ECH10OH-05			
	- 120					120		ECH10-05	ECH10OH-05		
	ECH13F - 60	AR20-d	AR20OH-d	1-13	35	60	37	-	-	NA20F	FK-5
	- 90					ECH13-05		ECH13OH-05			
	- 120					120		ECH13-05	ECH13OH-05		
	ECH16F - 60	AR25-d	AR25OH-d	1-16	42	60	41.5	-	-	NA25F	FK-6
	- 90					ECH16-05		ECH16OH-05			
- 120					120		ECH16-05	ECH16OH-05			
ECH20F - 60	AR32-d	AR32OH-d	3-20	50	60	47.5	-	-	NA32F	FK-7	
- 90					ECH20-05		ECH20OH-05				
ECH26F - 70	AR40-d	AR40OH-d	3-26	61.5	70	54.5	-	-	NA40F	FK-9	
C8	AC8- ECH10F - 70	AR16-d	AR16OH-d	1-10	30	70	33	ECH10-05	ECH10OH-05	NA16F	FK-4
	- 100										
	ECH13F - 70	AR20-d	AR20OH-d	1-13	35	70	37	ECH13-05	ECH13OH-05	NA20F	FK-5
	- 100										
	ECH16F - 70	AR25-d	AR25OH-d	1-16	42	70	41.5	-	-	NA25F	FK-6
	- 100					ECH16-05		ECH16OH-05			
ECH20F - 70	AR32-d	AR32OH-d	3-20	50	70	47.5	-	-	NA32F	FK-7	
- 100					ECH20-05		ECH20OH-05				
ECH26F - 70	AR40-d	AR40OH-d	3-26	61.5	70	54.5	-	-	NA40F	FK-9	

- ◆ NOTES ◆
- Slit through coolant becomes available by using AR collet (AR □□ -d)
  - Center through coolant becomes available by using AR coolant collet (AR □□ OH-d)
  - Please order a wrench separately.

## Micro float tapper AES-OHC type

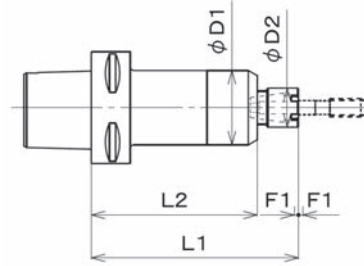
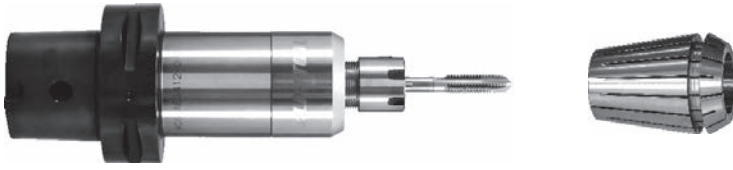

### ● Features

- Synchronous control machining.
- Carbide tapping.
- Supports gap through.
- Micro float tapper (with micro expansion/contraction)
- High-speed tapping.
- Compatible with high-pressure center coolant through, **pressure of 7MPa**.

### ● Form explanation

AC6-AES 412-OHC

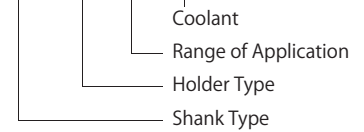

SIZE	CODE	I/F	Dimension				Float Quantity F 1	Capacity	Collet	Nut	Wrench
			L1	L2	φ D1	φ D2					
C3	AC3- AES412 -OHC	C3	117	93.7	42	22	± 0.5	M4 ~ M12	AR16	NA16M ※ 1	AE-16M AE16M-CS
C4	AC4- AES412 -OHC	C4									
C5	AC5- AES412 -OHC	C5									
C6	AC6- AES412 -OHC	C6	175	141.9	66	50		M10 ~ M22	AR32	NA32S ※ 2	FK-7
			AC6- AES1022 -OHC								
C8	AC8- AES1022 -OHC	C8	160	126.9							

- ◆ NOTES ◆ Compatible collets  
 ※ 1 : AR16GB-M4~M12, AR16GH-M5~M12  
 ※ 2 : AR32GB-M10~M22, AR32GH-M10~M22

## Micro float tapper HA-M-OHC type

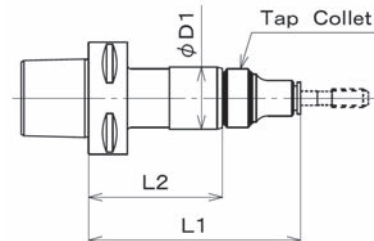

### ● Features

- Synchronous control machining.
  - Taps and tap collets can be attached and detached with a single touch.
  - Compatible with center coolant through.  
 Tap collet used...Model TC-MO (standard spec.) (**pressure 2 MPa**)  
 Model TC-MO-SB (**pressure 5 MPa**)
  - Micro float tapper (with micro expansion/contraction)
- ※ Mist specifications are also available (to be used with a tapped collet with holes).

### ● Form explanation

AC6-HA 412-M-OHC

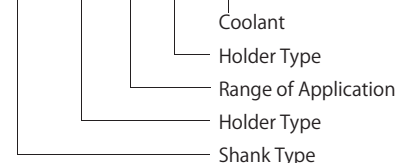

SIZE	CODE	I/F	Dimension			Capacity	Tap Collet	Tap Collet
			L1	L2	φ D1			
C6	AC6- HA412 -M-OHC	C6	120	76.5	35	M3 ~ M16	TC412 -MO	Made of KATO-KOKI
	AC6- HA1022 -M-OHC		165	100	50	M8 ~ M27	TC1022-MO	

- ◆ NOTES ◆ 1.L0 dimension is the standard value.  
 2.Specifications are subject to change without notice for improvement purposes.

## Radial float tapper ARF type

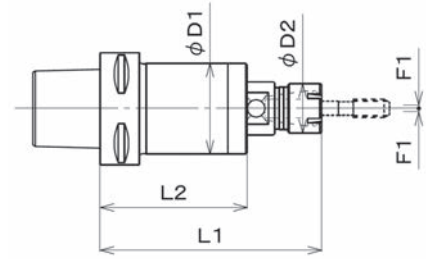

### ● Features

- Synchronous control machining.
- Radial float tapper.
- Absorbs core misalignment and enables vertical thread processing.
- Direct tapping possible for aluminum die-casting pilot holes.
- Used as reamer holder.

### ● Form explanation

AC6-ARF 414

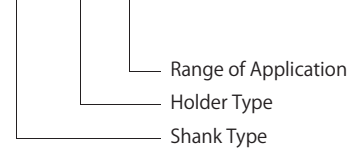

SIZE	CODE		Dimension				Float Quantity F 1	Capacity	Collet	Nut	Wrench	
			L1	L2	φ D1	φ D2						
C3	AC3-	ARF414	C3	115	73	51	28	± 1.0	M4 ~ M14	AR20	NA20M	AE-20M
C4	AC4-	ARF414	C4									
C5	AC5-	ARF414	C5									
C6	AC6-	ARF414	C6	125	83							

## Radial float tapper RA-M type

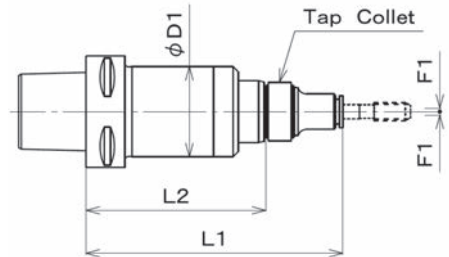

### ● Features

- Synchronous control machining.
- Radial float tapper.
- For machining centers and tapping centers.
- Automatic centering with a radius of 1 mm absorbs misalignment with the pilot hole.
- Ideal for when pilot holes are being machined by casting.

### ● Form explanation

AC6-RA 412 -M

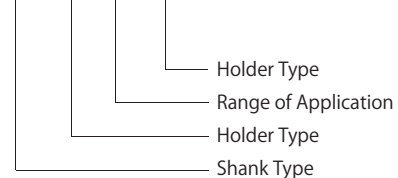

SIZE	CODE	I/F	Dimension			フロート量 F 1	Capacity	Tap Collet	Tap Collet	
			L1	L2	φ D1					
C6	AC6-	RA412 -M	C6	145	101.5	51	± 1.0	M4 ~ M12	TC412 -MO	Made by KATO-KOKI

- ◆ NOTES ◆
- 1.L0 dimension is the standard value.
  - 2.Specifications are subject to change without notice for improvement purposes.

Convenient multi-collet with gripping range of 0.5mm to 1mm.

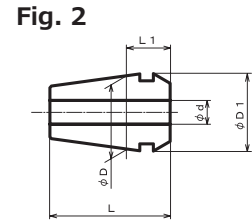
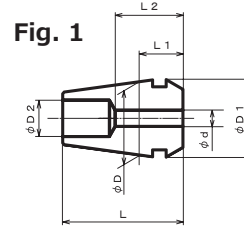
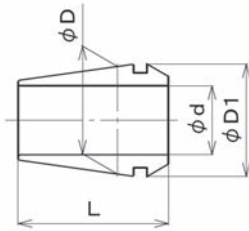
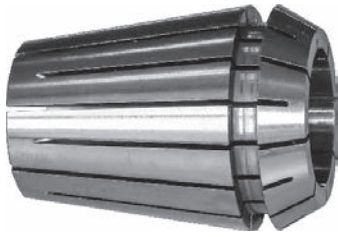

● Form explanation

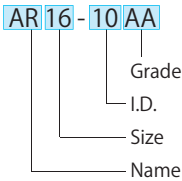

AR11				
L1=6.5, φ D=11, φ D1=11.5, L=18				
CODE	O.D. range	L2	φ D2	Fig.
AR11-1	1.0 ~ 0.5	10	5.5	1
AR11-1.5	1.5 ~ 1.0			
AR11-2	2.0 ~ 1.5			
AR11-2.5	2.5 ~ 2.0			
AR11-3	3.0 ~ 2.5			
AR11-3.175	3.175			
AR11-3.5	3.5 ~ 3.0			
AR11-4	4.0 ~ 3.5			
AR11-4.5	4.5 ~ 4.0			
AR11-5	5.0 ~ 4.5			
AR11-5.5	5.5 ~ 5.0			
AR11-6	6.0 ~ 5.5			
AR11-6.5	6.5 ~ 6.0			
AR11-7	7.0 ~ 6.5			
		-	-	2

AR16				
L1=10, φ D=16, φ D1=17, L=27				
CODE	O.D. range	L2	φ D2	Fig.
AR16-1	1.0 ~ 0.5	16	7.5	1
AR16-1.5	1.5 ~ 1.0			
AR16-2	2.0 ~ 1.5			
AR16-2.5	2.5 ~ 2.0			
AR16-3	3.0 ~ 2.5			
AR16-3.175	3.175			
AR16-3.5	3.5 ~ 3.0			
AR16-4	4.0 ~ 3.5			
AR16-4.5	4.5 ~ 4.0			
AR16-5	5.0 ~ 4.5			
AR16-6	6.0 ~ 5.0	-	-	2
AR16-7	7.0 ~ 6.0			
AR16-8	8.0 ~ 7.0			
AR16-9	9.0 ~ 8.0			
AR16-10	10.0 ~ 9.0			

AR20				
L1=11, φ D=20, φ D1=21, L=31				
CODE	O.D. range	L2	φ D2	Fig.
AR20-1	1.0 ~ 0.5	13	10	1
AR20-1.5	1.5 ~ 1.0	14		
AR20-2	2.0 ~ 1.5	18		
AR20-2.5	2.5 ~ 2.0			
AR20-3	3.0 ~ 2.5	19		
AR20-3.175	3.175			
AR20-3.5	3.5 ~ 3.0			
AR20-4	4.0 ~ 3.5	20		
AR20-4.5	4.5 ~ 4.0			
AR20-5	5.0 ~ 4.5	-		
AR20-6	6.0 ~ 5.0			
AR20-7	7.0 ~ 6.0			
AR20-8	8.0 ~ 7.0			
AR20-9	9.0 ~ 8.0			
AR20-10	10.0 ~ 9.0			
AR20-11	11.0 ~ 10.0			
AR20-12	12.0 ~ 11.0			
AR20-13	13.0 ~ 12.0			
AR20-14 ※	14.0 ~ 13.0			

※ \*You can't insert deep inside with AR20-14 because I.D. of collet holders is smaller than 14mm.

AR25				
L1=11.5, φ D=25, φ D1=26, L=35				
CODE	O.D. range	L2	φ D2	Fig.
AR25-1	1.0 ~ 0.5	14	13	1
AR25-1.5	1.5 ~ 1.0			
AR25-2	2.0 ~ 1.5			
AR25-2.5	2.5 ~ 2.0			
AR25-3	3.0 ~ 2.5			
AR25-3.5	3.5 ~ 3.0			
AR25-4	4.0 ~ 3.5			
AR25-4.5	4.5 ~ 4.0			
AR25-5	5.0 ~ 4.5			
AR25-6	6.0 ~ 5.0			
AR25-7	7.0 ~ 6.0	-	-	2
AR25-8	8.0 ~ 7.0			
AR25-9	9.0 ~ 8.0			
AR25-10	10.0 ~ 9.0			
AR25-11	11.0 ~ 10.0			
AR25-12	12.0 ~ 11.0			
AR25-13	13.0 ~ 12.0			
AR25-14	14.0 ~ 13.0			
AR25-15	15.0 ~ 14.0			
AR25-16	16.0 ~ 15.0			

AR32				
L1=12.5, φ D=32, φ D1=33, L=40				
CODE	O.D. range	L2	φ D2	Fig.
AR32-2.5	2.5 ~ 2.0	21	16	1
AR32-3	3.0 ~ 2.5			
AR32-3.5	3.5 ~ 3.0			
AR32-4	4.0 ~ 3.5			
AR32-4.5	4.5 ~ 4.0			
AR32-5	5.0 ~ 4.5			
AR32-6	6.0 ~ 5.0			
AR32-7	7.0 ~ 6.0			
AR32-8	8.0 ~ 7.0			
AR32-9	9.0 ~ 8.0			
AR32-10	10.0 ~ 9.0	-	-	2
AR32-11	11.0 ~ 10.0			
AR32-12	12.0 ~ 11.0			
AR32-13	13.0 ~ 12.0			
AR32-14	14.0 ~ 13.0			
AR32-15	15.0 ~ 14.0			
AR32-16	16.0 ~ 15.0			
AR32-17	17.0 ~ 16.0			
AR32-18	18.0 ~ 17.0			
AR32-19	19.0 ~ 18.0			
AR32-20	20.0 ~ 19.0			

AR40				
L1=14.5, φ D=40, φ D1=41, L=46				
CODE	O.D. range	L2	φ D2	Fig.
AR40-4	4.0 ~ 3.5	26	20	1
AR40-4.5	4.5 ~ 4.0			
AR40-5	5.0 ~ 4.5	27		
AR40-6	6.0 ~ 5.0			
AR40-7	7.0 ~ 6.0	28		
AR40-8	8.0 ~ 7.0			
AR40-9	9.0 ~ 8.0			
AR40-10	10.0 ~ 9.0	30		
AR40-11	11.0 ~ 10.0			
AR40-12	12.0 ~ 11.0	-		
AR40-13	13.0 ~ 12.0			
AR40-14	14.0 ~ 13.0			
AR40-15	15.0 ~ 14.0			
AR40-16	16.0 ~ 15.0			
AR40-17	17.0 ~ 16.0			
AR40-18	18.0 ~ 17.0			
AR40-19	19.0 ~ 18.0			
AR40-20	20.0 ~ 19.0			
AR40-21	21.0 ~ 20.0			
AR40-22	22.0 ~ 21.0			
AR40-23	23.0 ~ 22.0			
AR40-24	24.0 ~ 23.0			
AR40-25	25.0 ~ 24.0			
AR40-26	26.0 ~ 25.0			

D1	L	Accuracy by grade ( μ m)		
		AAA	AA	A
1~1.5	4 × D1	*(3) μ	*(5) μ	8 μ
2~5.5	4 × D1			
6~10	25			
11~26	40			

- ◆ NOTES
- Can be used with smaller shanktool than d.
  - When ordering, please indicate the precision grade at the end of the CODE.  
Ordering example: AR32-5 . . . A grade (with NO "A")  
AR32-5AA . . . AA grade  
AR32-5AAA . . . AAA grade  
Since grade A is the standard, there is no need to indicate the grade for Grade A.  
AA grade is available for AR11, 16, 20, 25, 32, and 40.  
AAA grade is available for AR11, 16, 20, 25, and 32.
  - I.D. shape varies depending on φ d.
  - When using AR20-14, the tool cannot be inserted to the depth of the holder.

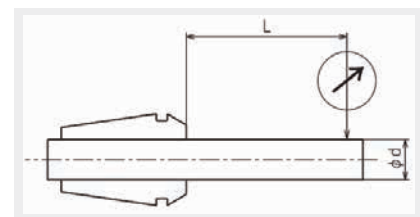



# AR/OH Coolant Collet

Available with oil hole drills and oil hole end mills.

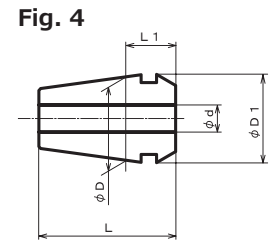
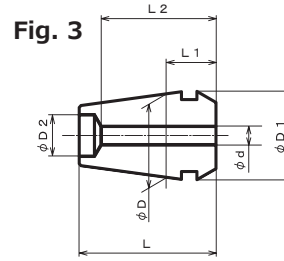
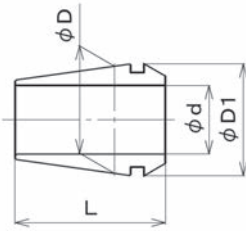

● Form explanation

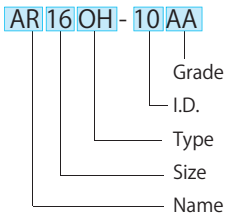

**Coolant Thru**

Center Thru Available

**20MPa Available**

AR11 OH				
L1=6.5, φ D=11, φ D1=11.5, L=18				
CODE	O.D. range	L2	φ D2	Fig.
AR11OH-2	2.0 ~ 1.9	-	-	4
AR11OH-2.5	2.5 ~ 2.4			
AR11OH-3	3.0 ~ 2.9			
AR11OH-3.5	3.5 ~ 3.4			
AR11OH-4	4.0 ~ 3.9			
AR11OH-4.5	4.5 ~ 4.4			
AR11OH-5	5.0 ~ 4.9			
AR11OH-5.5	5.5 ~ 5.4			
AR11OH-6	6.0 ~ 5.9			
AR11OH-6.5	6.5 ~ 6.4			
AR11OH-7	7.0 ~ 6.9			

AR16 OH				
L1=10, φ D=16, φ D1=17, L=27				
CODE	O.D. range	L2	φ D2	Fig.
AR16OH-2	2.0 ~ 1.9	-	-	4
AR16OH-2.5	2.5 ~ 2.4			
AR16OH-3	3.0 ~ 2.9			
AR16OH-3.5	3.5 ~ 3.4			
AR16OH-4	4.0 ~ 3.9			
AR16OH-4.5	4.5 ~ 4.4			
AR16OH-5	5.0 ~ 4.9			
AR16OH-5.5	5.5 ~ 5.4			
AR16OH-6	6.0 ~ 5.5			
AR16OH-6.5	6.5 ~ 6.0			
AR16OH-7	7.0 ~ 6.5			
AR16OH-7.5	7.5 ~ 7.0			
AR16OH-8	8.0 ~ 7.5			
AR16OH-8.5	8.5 ~ 8.0			
AR16OH-9	9.0 ~ 8.5			
AR16OH-9.5	9.5 ~ 9.0			
AR16OH-10	10.0 ~ 9.5			

AR20 OH				
L1=11, φ D=20, φ D1=21, L=31				
型式	O.D. range	L2	φ D2	Fig.
CODE	O.D. range	L2	φ D2	Fig.
AR20OH-3	3.0 ~ 2.9	24	10	3
AR20OH-3.5	3.5 ~ 3.4			
AR20OH-4	4.0 ~ 3.9			
AR20OH-4.5	4.5 ~ 4.4	25	10	3
AR20OH-5	5.0 ~ 4.9			
AR20OH-5.5	5.5 ~ 5.4			
AR20OH-6	6.0 ~ 5.5	-	-	4
AR20OH-6.5	6.5 ~ 6.0			
AR20OH-7	7.0 ~ 6.5			
AR20OH-7.5	7.5 ~ 7.0			
AR20OH-8	8.0 ~ 7.5			
AR20OH-8.5	8.5 ~ 8.0			
AR20OH-9	9.0 ~ 8.5			
AR20OH-9.5	9.5 ~ 9.0			
AR20OH-10	10.0 ~ 9.5			
AR20OH-10.5	10.5 ~ 10.0			
AR20OH-11	11.0 ~ 10.5			
AR20OH-11.5	11.5 ~ 11.0			
AR20OH-12	12.0 ~ 11.5			
AR20OH-12.5	12.5 ~ 12.0			
AR20OH-13	13.0 ~ 12.5			

AR25 OH				
L1=11.5, φ D=25, φ D1=26, L=35				
CODE	O.D. range	L2	φ D2	Fig.
AR25OH-3	3.0 ~ 2.9	23	13	3
AR25OH-3.5	3.5 ~ 3.4			
AR25OH-4	4.0 ~ 3.9			
AR25OH-4.5	4.5 ~ 4.4	27	13	3
AR25OH-5	5.0 ~ 4.9			
AR25OH-5.5	5.5 ~ 5.4			
AR25OH-6	6.0 ~ 5.5	28	13	3
AR25OH-6.5	6.5 ~ 6.0			
AR25OH-7	7.0 ~ 6.5			
AR25OH-7.5	7.5 ~ 7.0	29	13	3
AR25OH-8	8.0 ~ 7.5			
AR25OH-8.5	8.5 ~ 8.0			
AR25OH-9	9.0 ~ 8.5	-	-	4
AR25OH-9.5	9.5 ~ 9.0			
AR25OH-10	10.0 ~ 9.5			
AR25OH-10.5	10.5 ~ 10.0			
AR25OH-11	11.0 ~ 10.5			
AR25OH-11.5	11.5 ~ 11.0			
AR25OH-12	12.0 ~ 11.5			
AR25OH-12.5	12.5 ~ 12.0			
AR25OH-13	13.0 ~ 12.5			
AR25OH-13.5	13.5 ~ 13.0			
AR25OH-14	14.0 ~ 13.5			
AR25OH-14.5	14.5 ~ 14.0			
AR25OH-15	15.0 ~ 14.5			
AR25OH-15.5	15.5 ~ 15.0			
AR25OH-16	16.0 ~ 15.5			

AR32 OH				
L1=12.5, φ D=32, φ D1=33, L=40				
CODE	O.D. range	L2	φ D2	Fig.
AR32OH-3	3.0 ~ 2.9	26	16	3
AR32OH-3.5	3.5 ~ 3.4			
AR32OH-4	4.0 ~ 3.9			
AR32OH-4.5	4.5 ~ 4.4	30	16	3
AR32OH-5	5.0 ~ 4.9			
AR32OH-5.5	5.5 ~ 5.4			
AR32OH-6	6.0 ~ 5.9	31	16	3
AR32OH-6.5	6.5 ~ 6.4			
AR32OH-7	7.0 ~ 6.9			
AR32OH-7.5	7.5 ~ 7.4	32	16	3
AR32OH-8	8.0 ~ 7.5			
AR32OH-8.5	8.5 ~ 8.0			
AR32OH-9	9.0 ~ 8.5	33	16	3
AR32OH-9.5	9.5 ~ 9.0			
AR32OH-10	10.0 ~ 9.5			
AR32OH-10.5	10.5 ~ 10.0	-	-	4
AR32OH-11	11.0 ~ 10.5			
AR32OH-11.5	11.5 ~ 11.0			
AR32OH-12	12.0 ~ 11.5			
AR32OH-12.5	12.5 ~ 12.0			
AR32OH-13	13.0 ~ 12.5			
AR32OH-13.5	13.5 ~ 13.0			
AR32OH-14	14.0 ~ 13.5			
AR32OH-14.5	14.5 ~ 14.0			
AR32OH-15	15.0 ~ 14.5			
AR32OH-15.5	15.5 ~ 15.0			
AR32OH-16	16.0 ~ 15.5			
AR32OH-16.5	16.5 ~ 16.0			
AR32OH-17	17.0 ~ 16.5			
AR32OH-17.5	17.5 ~ 17.0			
AR32OH-18	18.0 ~ 17.5			
AR32OH-18.5	18.5 ~ 18.0			
AR32OH-19	19.0 ~ 18.5			
AR32OH-19.5	19.5 ~ 19.0			
AR32OH-20	20.0 ~ 19.5			

AR40 OH				
L1=14.5, φ D=40, φ D1=41, L=46				
CODE	O.D. range	L2	φ D2	Fig.
AR40OH-10	10.0 ~ 9.5	36	16	3
AR40OH-10.5	10.5 ~ 10.0			
AR40OH-11	11.0 ~ 10.5			
AR40OH-11.5	11.5 ~ 11.0	37	16	3
AR40OH-12	12.0 ~ 11.5			
AR40OH-12.5	12.5 ~ 12.0			
AR40OH-13	13.0 ~ 12.5	38	16	3
AR40OH-13.5	13.5 ~ 13.0			
AR40OH-14	14.0 ~ 13.5			
AR40OH-14.5	14.5 ~ 14.0	-	-	4
AR40OH-15	15.0 ~ 14.5			
AR40OH-15.5	15.5 ~ 15.0			
AR40OH-16	16.0 ~ 15.5			
AR40OH-16.5	16.5 ~ 16.0			
AR40OH-17	17.0 ~ 16.5			
AR40OH-17.5	17.5 ~ 17.0			
AR40OH-18	18.0 ~ 17.5			
AR40OH-18.5	18.5 ~ 18.0			
AR40OH-19	19.0 ~ 18.5			
AR40OH-19.5	19.5 ~ 19.0			
AR40OH-20	20.0 ~ 19.5			
AR40OH-20.5	20.5 ~ 20.0			
AR40OH-21	21.0 ~ 20.5			
AR40OH-21.5	21.5 ~ 21.0			
AR40OH-22	22.0 ~ 21.5			
AR40OH-22.5	22.5 ~ 22.0			
AR40OH-23	23.0 ~ 22.5			
AR40OH-23.5	23.5 ~ 23.0			
AR40OH-24	24.0 ~ 23.5			
AR40OH-24.5	24.5 ~ 24.0			
AR40OH-25	25.0 ~ 24.5			
AR40OH-25.5	25.5 ~ 25.0			
AR40OH-26	26.0 ~ 25.5			

- ◆ NOTES ◆
1. Other nominal dimensions are made-to-order, and only the specified size can be used. Minimum order of 3 pieces per size.
  2. For oil hole (OH) drills.
  3. When using, insert the drill deeper than the collet end face.
  4. The inside diameter shape differs depending on φ d.
  5. If a collet of a size other than the nominal diameter is gripped, coolant may seep out or a small amount of leakage may occur.
  6. The sealing function of the collet does not work when a straight shank with a flat edge is used.

AR collet for taps that securely locks the corners of the tap.

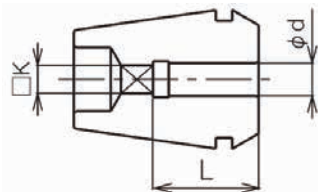

● Form explanation

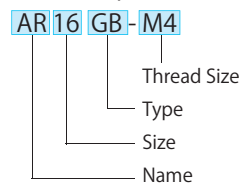

AR16GB						
CODE	Tap Size			d	K	L
	Metric	Unified	Pipe Thread			
AR16GB-M4	M4	(No.8U)		5	4	15
AR16GB-M5	M5	(No10U/12U)		5.5	4.5	
AR16GB-M6	M6	(1/4U)		6	4.5	
AR16GB-5/16U	-	5/16U	-	6.1	5	20
AR16GB-M8	M8	-	6.2	5		
AR16GB-M10	M10	(3/8U)	PT1/8(1/16)	7	5.5	20
AR16GB-7/16U	(M11)	7/16U		8	6	
AR16GB-PT1/8	-	-		8.5	6.5	
AR16GB-M12	M12	-	-	8.5	6.5	

AR20GB						
CODE	Tap Size			d	K	L
	Metric	Unified	Pipe Thread			
AR20GB-M4	M4	(No.8U)		5	4	15
AR20GB-M5	M5	(No10U/12U)		5.5	4.5	
AR20GB-M6	M6	(1/4U)		6	4.5	
AR20GB-5/16U	-	5/16U	-	6.1	5	20
AR20GB-M8	M8	-	6.2	5		
AR20GB-M10	M10	(3/8U)	PT1/8(1/16)	7	5.5	21
AR20GB-7/16U	(M11)	7/16U		8	6	
AR20GB-PT1/8	-	-		8.5	6.5	
AR20GB-M12	M12	-	-	8.5	6.5	21
AR20GB-1/2U	-	1/2U	-	9	7	

AR25GB						
CODE	Tap Size			d	K	L
	Metric	Unified	Pipe Thread			
AR25GB-M4	M4	(No.8U)		5	4	15
AR25GB-M5	M5	(No10U/12U)		5.5	4.5	
AR25GB-M6	M6	(1/4U)		6	4.5	
AR25GB-5/16U	-	5/16U	-	6.1	5	20
AR25GB-M8	M8	-	6.2	5		
AR25GB-M10	M10	(3/8U)	PT1/8(1/16)	7	5.5	25
AR25GB-7/16U	(M11)	7/16U		8	6	
AR25GB-PT1/8	-	-		8.5	6.5	
AR25GB-M12	M12	-	-	9	7	25
AR25GB-1/2U	-	1/2U	-	10.5	8	
AR25GB-M14	M14	(9/16U)	PT1/4	11	9	17
AR25GB-PT1/4	-	-		12	9	
AR25GB-5/8U	-	5/8U		12.5	10	
AR25GB-M16	M16	-	PT3/8	12.5	10	25
AR25GB-PT3/8	-	-		14	11	

AR32GB						
CODE	Tap Size			d	K	L
	Metric	Unified	Pipe Thread			
AR32GB-M4	M4	(No.8U)		5	4	15
AR32GB-M5	M5	(No10U/12U)		5.5	4.5	
AR32GB-M6	M6	(1/4U)		6	4.5	
AR32GB-5/16U	-	5/16U	-	6.1	5	20
AR32GB-M8	M8	-	6.2	5		
AR32GB-M10	M10	(3/8U)	PT1/8(1/16)	7	5.5	25
AR32GB-7/16U	(M11)	7/16U		8	6	
AR32GB-PT1/8	-	-		8.5	6.5	
AR32GB-M12	M12	-	-	9	7	25
AR32GB-1/2U	-	1/2U	-	10.5	8	
AR32GB-M14	M14	(9/16U)	PT1/4	11	9	17
AR32GB-PT1/4	-	-		12	9	
AR32GB-5/8U	-	5/8U		12.5	10	
AR32GB-M16	M16	-	PT3/8	12.5	10	25
AR32GB-PT3/8	-	-		14	11	
AR32GB-M18	M18	(3/4U)		14	11	28
AR32GB-M20	M20	-		15	12	
AR32GB-M22	M22	-		17	13	

AR40GB						
CODE	Tap Size			d	K	L
	Metric	Unified	Pipe Thread			
AR40GB-M10	M10	(3/8U)		7	5.5	25
AR40GB-7/16U	(M11)	7/16U		8	6	
AR40GB-PT1/8	-	-		8.5	6.5	
AR40GB-M12	M12	-	PT1/8(1/16)	9	7	25
AR40GB-1/2U	-	1/2U		10.5	8	
AR40GB-M14	M14	(9/16U)	PT1/4	11	9	17
AR40GB-PT1/4	-	-		12	9	
AR40GB-5/8U	-	5/8U		12.5	10	
AR40GB-M16	M16	-	PT3/8	12.5	10	25
AR40GB-PT3/8	-	-		14	11	
AR40GB-M18	M18	(3/4U)		14	11	28
AR40GB-M20	M20	-		15	12	
AR40GB-M22	M22	(7/8U)		17	13	
AR40GB-PT1/2	-	-	PT1/2	18	14	21
AR40GB-M24	M24	-		19	15	
AR40GB-M27	M27	(1U)	-	20	15	31

AR50GB						
CODE	Tap Size			d	K	L
	Metric	Unified	Pipe Thread			
AR50GB-M10	M10	(3/8U)		7	5.5	25
AR50GB-7/16U	(M11)	7/16U		8	6	
AR50GB-PT1/8	-	-		8.5	6.5	
AR50GB-M12	M12	-	PT1/8(1/16)	9	7	25
AR50GB-1/2U	-	1/2U		10.5	8	
AR50GB-M14	M14	(9/16U)	PT1/4	11	9	17
AR50GB-PT1/4	-	-		12	9	
AR50GB-5/8U	-	5/8U		12.5	10	
AR50GB-M16	M16	-	PT3/8	12.5	10	25
AR50GB-PT3/8	-	-		14	11	
AR50GB-M18	M18	(3/4U)		14	11	28
AR50GB-M20	M20	-		15	12	
AR50GB-M22	M22	(7/8U)		17	13	
AR50GB-PT1/2	-	-	PT1/2	18	14	21
AR50GB-M24	M24	-		19	15	
AR50GB-M27	M27	(1U)		20	15	35
AR50GB-M28	M28	-		21	17	

# AR/GH Coolant Tap Collet

AR coolant collet for taps that securely locks the corner of the tap.

Coolant Thru

Center Thru

20MPa Available

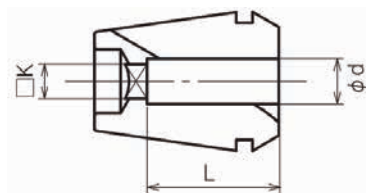

● Form explanation

AR16 GH-M6  
 Name: AR16  
 Size: GH  
 Type: M6  
 Thread Size: M6

AR16GH						
CODE	Tap Size			d	K	L
	Metric	Unified	Pipe Thread			
AR16GH-M5	M5	-	-	5.5	4.5	22
AR16GH-M6	M6	(1/4U)		6	4.5	
AR16GH-5/16U	-	5/16U		6.1	5	
AR16GH-M8	M8	-		6.2		
AR16GH-M10	M10	(3/8U)		7	5.5	
AR16GH-7/16U	(M11)	7/16U		8	6	
AR16GH-PT1/8	-	PT1/8(1/16)				
AR16GH-M12	M12	-				

AR20GH						
CODE	Tap Size			d	K	L
	Metric	Unified	Pipe Thread			
AR20GH-M6	M6	(1/4U)	-	6	4.5	25
AR20GH-5/16U	-	5/16U		6.1	5	
AR20GH-M8	M8	-		6.2		
AR20GH-M10	M10	(3/8U)		7	5.5	
AR20GH-7/16U	(M11)	7/16U		8	6	
AR20GH-PT1/8	-	PT1/8(1/16)				
AR20GH-M12	M12	-				
AR20GH-1/2U	-	1/2U		-	9	

AR25GH						
CODE	Tap Size			d	K	L
	Metric	Unified	Pipe Thread			
AR25GH-M6	M6	(1/4U)	-	6	4.5	25
AR25GH-5/16U	-	5/16U		6.1	5	
AR25GH-M8	M8	-		6.2		
AR25GH-M10	M10	(3/8U)		7	5.5	
AR25GH-7/16U	(M11)	7/16U		8	6	
AR25GH-PT1/8	-	PT1/8(1/16)				
AR25GH-M12	M12	-				
AR25GH-1/2U	-	1/2U		-	9	
AR25GH-M14	M14	(9/16U)	-	10.5	8	30
AR25GH-PT1/4	-	PT1/4		11	9	
AR25GH-5/8U	-	5/8U		12		
AR25GH-M16	M16	-		12.5	10	
AR25GH-PT3/8	-	-	PT3/8	14	11	

AR32GH						
CODE	Tap Size			d	K	L
	Metric	Unified	Pipe Thread			
AR32GH-M6	M6	(1/4U)	-	6	4.5	25
AR32GH-5/16U	-	5/16U		6.1	5	
AR32GH-M8	M8	-		6.2		
AR32GH-M10	M10	(3/8U)		7	5.5	
AR32GH-7/16U	(M11)	7/16U		8	6	
AR32GH-PT1/8	-	PT1/8(1/16)				
AR32GH-M12	M12	-				
AR32GH-1/2U	-	1/2U		-	9	
AR32GH-M14	M14	(9/16U)	-	10.5	8	30
AR32GH-PT1/4	-	PT1/4		11	9	
AR32GH-5/8U	-	5/8U		12		
AR32GH-M16	M16	-		12.5	10	
AR32GH-PT3/8	-	-	PT3/8	14	11	
AR32GH-M18	M18	(3/4U)	-	15	12	35
AR32GH-M20	M20	-		17	13	
AR32GH-M22	M22	-		17	13	

AR40GH								
CODE	Tap Size			d	K	L		
	Metric	Unified	Pipe Thread					
AR40GH-M10	M10	(3/8U)	-	7	5.5	30		
AR40GH-7/16U	(M11)	7/16U		8	6			
AR40GH-PT1/8	-	PT1/8(1/16)		8.5			6.5	
AR40GH-M12	M12	-						
AR40GH-1/2U	-	1/2U			9			7
AR40GH-M14	M14	(9/16U)		-	10.5		8	35
AR40GH-PT1/4	-	PT1/4			11		9	
AR40GH-5/8U	-	5/8U			12			
AR40GH-M16	M16	-	12.5		10			
AR40GH-PT3/8	-	-	PT3/8	14	11			
AR40GH-M18	M18	(3/4U)	-	15	12	40		
AR40GH-M20	M20	-		17	13			
AR40GH-M22	M22	(7/8U)		17	13			
AR40GH-PT1/2	-	-	PT1/2	18	14			
AR40GH-M24	M24	-	-	19	15			
AR40GH-M27	M27	(1U)		20				

◆ NOTES ◆

- The above chart is based on JIS Standard. ANSI, DIN, the ISO shank or when using the tap size not listed in the catalog, please contact to "ALPS TOOL".
- Each suitable collet is required for each tap size.
- When tapping with machine synchronized feed(synchro-Tap), above tap collet with ECH collet holder can be used for tapping.
- Inner diameter shape differs depending on the size d.
- AR50GB is order made.
- When you use GH type, please make sure the cutting tool is put into the bottom inside of the collet hole.

Coolant through is available on drills and endmills without oil hole.



● Form explanation

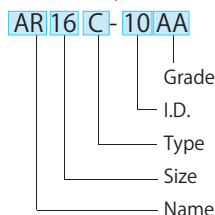

Coolant Thru

20MPa Available

Made to order

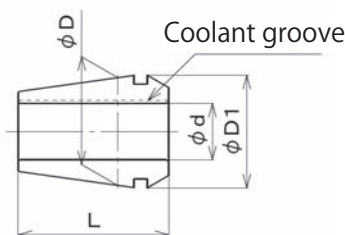

Code	d		D	L	Applicable Holder Type
	Range	Clamping Range			
AR11C-d	3~7	0.1	11	18	EXH7
AR16C-d	3~5.9	0.1	16	27	EXH10
	6~10	0.5			
AR20C-d	5~5.9	0.1	20	31	EXH13
	6~13	0.5			
AR25C-d	6~16	0.5	25	35	EXH16
AR32C-d	8~20	0.5	32	40	EXH20

- ◆ Correspond for high-pressure coolant sealing can be done by high-pressure of 20MPa except for the coolant groove.
- ◆ Coolant is sprayed toward the cutting edge, making it easy to reduce chip removal.
- ◆ Effective for deep drilling of small diameter hole.
- ◆ For water-soluble or oil coolant available.
- ◆ It is also suitable for semi-dry machining (mist).

◆ NOTES ◆

1. AR/C collets are made to order.
2. Compatible with water-soluble coolant. We offer oil-based coolant.
3. When ordering, please specify the runout accuracy grade and oil type at the end of the model number.  
Ordering example: AR16 C -6.0 ... For water-soluble coolant φ 6, grade A  
AR16CY-6.0AA... For oil-based coolant φ 6, grade AA
4. Drill should be inserted deeper the depth of the collet.
5. When gripping a collet of a size other than the diameter, coolant may seep out or a small amount of coolant may leak.
6. The sealing of the collet does not work when a straight shank with a flat edge is used.
7. The inside diameter shape varies depending on φ d.

## Recommended torque for tightening the nut

Code	Size	Torgue	Holder Size
AR 8	φ 0.5 ~ * < φ 3.5	7	ECH 5
	φ 3.5 ~ φ 5.0	10	
AR11	φ 1.0 ~ < φ 3.5	15	ECH 7
	φ 3.5 ~ φ 7.0	20	
AR16	φ 1.0 ~ < φ 3.5	30	ECH10
	φ 3.5 ~ φ 10.0	40	
AR20	φ 1.0 ~ < φ 3.5	40	ECH13
	φ 3.5 ~ φ 14.0	60	
AR25	φ 1.0 ~ < φ 3.5	40	ECH16
	φ 3.5 ~ φ 16.0	60	
AR32	φ 3.0 ~ φ 20.0	70	ECH20
AR40	φ 4.0 ~ φ 26.0	80	ECH26
AR50	φ 6.0 ~ φ 34.0	140	ECH34

\* < = less than  
φ 0.5 - < φ 3.5 is φ 0.5 to less than φ 3.5.

◆ NOTES ◆

1. Excessive tightening may cause damage to the holder body, nut, or collet.
2. The recommended torques listed in the table above are only for reference. They do not guarantee machining accuracy.
3. Use of a torque wrench is recommended for tightening nuts.



# TR type Milling Chuck Adapter

For heavy-duty cutting such as roughing end mills.

**Coolant Thru**

Center Thru / Side Thru Available

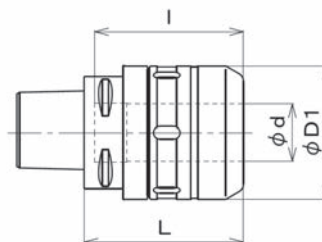

SIZE	CODE	Collet CODE	Dimension				Wrench
			φ d	φ D1	L	I	
C4	AC4- TRX16 - 70	AS16-d	16	45	70	65	FK-7
	TRX20 - 75	AS20-d	20	52	75	69	FK-8
C5	AC5- TRX16 - 70	AS16-d	16	45	70	65	FK-7
	- 90				90		
	TRX20 - 75	AS20-d	20	52	75	70	FK-8
	- 90				90		
	TRX25 - 80	AS25-d	25	63	80	76	FK-9
	-105				105		
TRX32 - 85	AS32-d	32	75	85	77	FK-10	
C6	AC6- TRX16 - 70	AS16-d	16	45	70	65	FK-7
	- 90				90		
	-105				105		
	-135				135		
	TRX20 - 75	AS20-d	20	52	75	71	FK-8
	- 90				90		
	-105				105		
	-135				135		
	TRX25 - 80	AS25-d	25	63	80	76	FK-9
	-105				105		
	-135				135		
	TRX32 - 90				AS32-d		
	-105	105					
	-135	135					
TRX42 -100	AS42-d	42	92	100		90	FK-12
C8	AC8- TRX16 -105	AS16-d	16	45	105	65	FK-7
	-135				135		
	-165				165		
	TRX20 - 85				AS20-d		
	-105	105					
	-135	135					
	-165	165					
	TRX25 - 90	AS25-d	25	63	90	80	FK-9
	-105				105		
	-135				135		
	-165				165		
	TRX32 -100	AS32-d	32	75	100	90	FK-10
	-105				105		
	-135				135		
	-165				165		
	TRX42 -105	AS42-d	42	92	105	95	FK-12



Center Thru



Side Thru

● Form explanation

AC6-TRX 16- 70

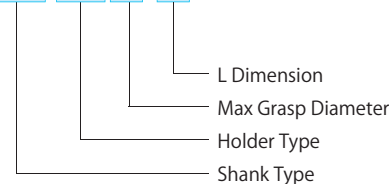

◆ NOTES ◆

- Center through coolant is available as standard.
- Side through coolant becomes available by removing set bolt from the end face.
- When clamping the draw bolt, some shanks cannot be clamped if they are inserted too far into the adapter.
- Please order a wrench separately.

**Wrench**

FK- □



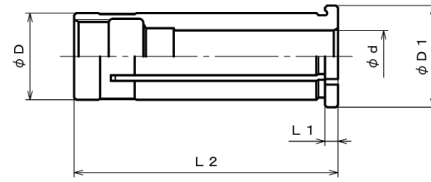

CODE	Dimension				
	$\varphi d$	$\varphi D$	$\varphi D1$	L1	L2
AS16-d	6, 8, 10, 12	16	20.0	3	48
AS20-d	6, 8, 10, 12, 16	20	23.5		61
AS25-d	6, 8, 10, 12, 16, 20	25	28.5		63
AS32-d	6, 8, 10, 12, 16, 20, 25	32	37.0		70
AS42-d	6, 8, 10, 12, 16, 20, 25, 32	42	47.0		78

● Form explanation

AS 16 - 10

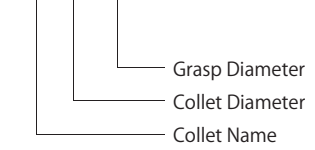

## Face Mill Adapter

The arbor compatible with JIS B4133 face mill.

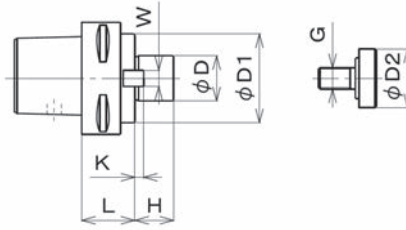

SIZE	CODE	Dimension								
		φ D	φ D1	L	H	W	K	φ D2	G	
C4	AC4 - FMA25.4 - 35	25.4	50	35	22	9.5	5	33	M12	
C5	AC5 - FMA25.4 - 30			30						
	FMA31.75 - 35	31.75	60	35	30	12.7	7	40	M16	
C6	AC6 - FMA25.4 - 30	25.4	50	30	22	9.5	5	33	M12	
	- 60			60						
	- 90			90						
		FMA31.75 - 30	31.75	60	30	30	12.7	7	40	M16
	- 90	90								
	FMA38.1 - 40	38.1	80	40	34	15.9	9	50	M20	
C8	AC8 - FMA25.4 - 40	25.4	50	40	22	9.5	5	33	M12	
	- 75			75						
	- 105			105						
		FMA31.75 - 40	31.75	60	40	30	12.7	7	40	M16
		- 90			90					
		FMA38.1 - 40	38.1	80	40	34	15.9	9	50	M20
	FMA50.8 - 50	50.8	100	50	36	19.05	10	65	M24	

● Form explanation

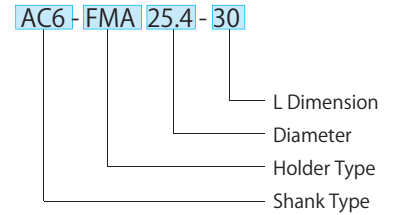

## Side Lock Adapter

For use with boring bars and U-drills.

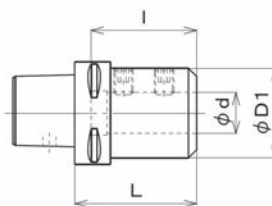

SIZE	CODE	Dimension			
		φ d	φ D1	L	l
C5	AC5- SLA20 - 65	20	50	65	60
	SLA25 - 75	25	55	75	65
	SLA32 - 80	32	60	80	70
	SLA40 -100	40	66	100	72
C6	AC6- SLA20 - 70	20	50	70	60
	SLA25 - 75	25	55	75	65
	SLA32 - 80	32	60	80	70
	SLA40 - 85	40	66	85	75
	SLA42 - 85	42	70	85	75
C8	AC8- SLA20 - 80	20	50	80	65
	SLA25 - 85	25	55	85	70
	SLA32 - 90	32	60	90	75
	SLA40 - 95	40	66	95	80
	SLA42 - 95	42	70	95	80

● Form explanation

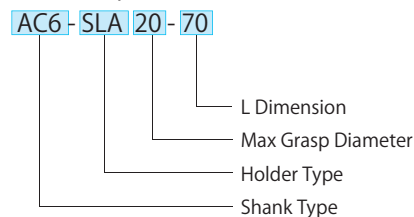

# Square Shank Adapter (Type B / Type C)

## Square Shank Adapter (B type)



● Form explanation

AC6- BHB 25 L - 90

L Dimension  
Handed  
Bite Size  
Holder Type  
Shank Type

● Form explanation

AC6- ABSB101-622 L0

Handed  
Holder Type  
Shank Type

● FIG.1

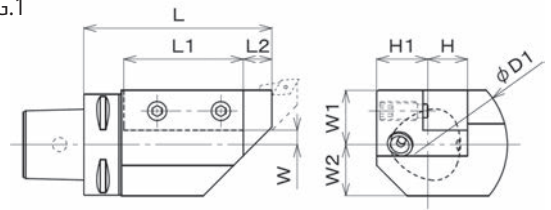

● FIG.2

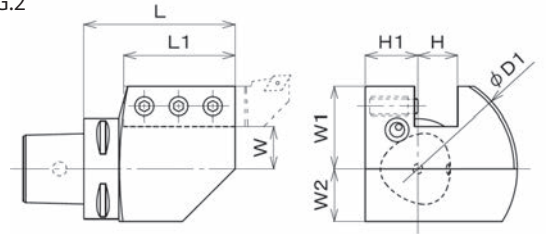

SIZE	CODE	FIG.	Bite Size	Dimension								
				$\phi$ D1 (interference range)	L	L1	L2	H	H1	W	W1	W2
C3	AC3- ABSB101 -322L0/R0	2	16	80	68	50	-	16	20	16	32	18
C4	AC4- ABSB101 -422L0/R0		20	100	80	57.5	-	20	22	20	40	22
C5	AC5- ABSB101 -522L0/R0		25	110	90	67	-	25	27	18	43	27
C6	AC6- ABSB101 -622L0/R0		125	95	70	-	25	33	26.5	51.5	33	
C8	AC8- ABSB101 -822L0/R0	1	32	145	110	77	-	32	41	28	60	41
C5	AC5- BHB20L/R - 90		20	90	105	67	15	20	26	6	26	26
C6	AC6- BHB25L/R -100		25	100	118	75	18	25	32	9	34	32
	-100MJ					65						
C8	AC8- BHB32L/R -110	32	130	133	77	23	32	42	10	42	42	

- ◆ NOTES ◆
- At the end of the code, "L" means left-handed and "R" means right-handed.  
Example: AC4-ABSB101-422L0...left-handed, AC4-ABSB101-422R0...right-handed  
AC6-BHB25L-100...left-handed, AC6-BHB25R-100...right-handed
  - Some machines cannot be used due to restrictions on tool height lower diameter.

## Square Shank Adapter (C type)



● Form explanation

AC6- BHC 25 - 130

L Dimension  
Bite Size  
Holder Type  
Shank Type

● Form explanation

AC6- ABSB101-621 L0

Handed  
Holder Type  
Shank Type

● FIG.1

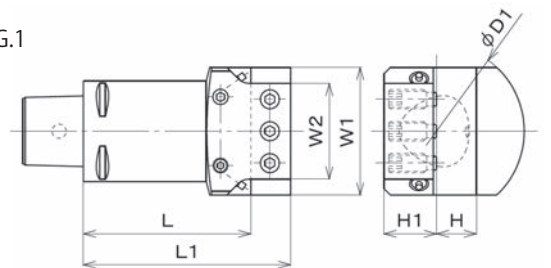

● FIG.2

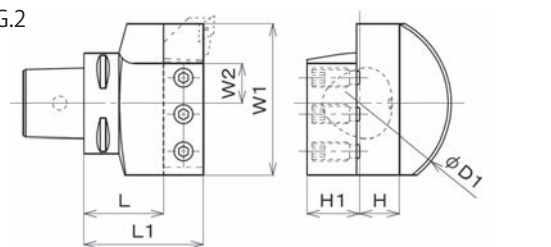

SIZE	CODE	FIG.	Bite Size	Dimension						
				$\phi$ D1 (interference range)	L1	L	H	H1	W1	W2
C3	AC3- ABSB101 -321L0/R0	2	16	76	48	32	16	20	48	16
C4	AC4- ABSB101 -421L0/R0		20	95	60	40	20	22	80	20
C5	AC5- ABSB101 -521L0/R0		25	110	70	45	25	27	90	25
C6	AC6- ABSB101 -621L0/R0		115	75	50	25	33	95	25	
C8	AC8- ABSB101 -821L0/R0	1	32	140	95	63	32	41	110	25
C5	AC5- BHC20 -110		20	100	110	90	20	27	80	60
C6	AC6- BHC25 -130		25	110	130	105	25	33	80	60
C8	AC8- BHC32 -140		32	140	140	108	32	42	100	78

- ◆ NOTES ◆
- At the end of the code, "L" means left-handed and "R" means right-handed.  
Example: AC4-ABSB101-422L0...left-handed, AC4-ABSB101-422R0...right-handed
  - Some machines cannot be used due to restrictions on tool height lower diameter.



## Morse Taper Adapter

For Morse taper shank drills.

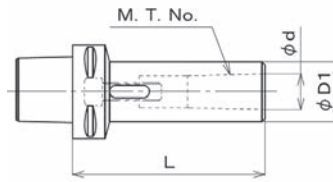

● Form explanation

AC6- MTA 1 - 95

L Dimension  
Morse Taper  
Holder Type  
Shank Type

SIZE	CODE	Morse Taper	Dimension			Pull thread cap screw
			φ D1	φ d	L	
C3	AC3- MTA1 - 90	1	25	12.065	90	M6 × 30
	MTA2 - 95	2	32	17.78	95	Not Available
C4	AC4- MTA1 - 90	1	25	12.065	90	M6 × 30
	MTA2 - 95	2	32	17.78	95	Not Available
	MTA3 - 115	3	40	23.825	115	
C5	AC5- MTA1 - 95	1	25	12.065	95	M6 × 35
	MTA2 -105	2	32	17.78	105	M10 × 35 (Special)
	MTA3 -115	3	40	23.825	115	Not Available
	MTA4 -145	4	52	31.267	145	
C6	AC6- MTA1 - 95	1	25	12.065	95	M6 × 35
	MTA2 -110	2	32	17.78	110	M10 × 35
	MTA3 -130	3	40	23.825	130	M12 × 40 (Special)
	MTA4 -150	4	52	31.267	150	Not Available
	MTA5 -180	5	68	44.339	180	
C8	AC8- MTA1 - 85	1	25	12.065	85	M6 × 30
	MTA2 -100	2	32	17.78	100	M10 × 35
	MTA3 -120	3	40	23.825	120	M12 × 40 (Special)
	MTA4 -150	4	52	31.267	150	Not Available
	MTA5 -185	5	68	44.339	185	

◆ NOTES ◆ 1. Please order pull screws separately.

## Shrink Fit Chuck Adapter

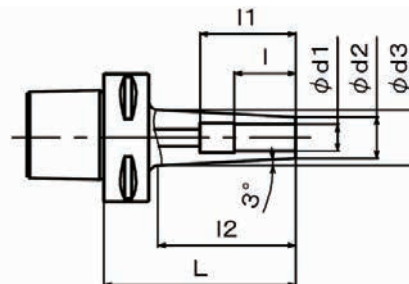

### Coolant Thru

Center Thru / Side Thru Available

● Form explanation

AC5- TG 6 M - 105

L Dimension  
Tip Shape  
Max Grasp Diameter  
Holder Type  
Shank Type

SIZE	CODE	Tool material	Dimension						
			φ d1	L	φ d2	φ d3	l4	l1	
C4	AC4- TG 6M - 70	Carbide	6	70	12	17.2	21	36 or longer	
	TG 8M - 70		8		14	19.2	25		
	TG10M - 70		10		16	21.2	31		
	TG12M4 - 70		12		20	25.2	34		
C5	AC5- TG 6M -105		105	6	105	12	20.9	21	36 or longer
	TG 8M -105			8		14	22.9	25	
	TG10M -105			10		16	24.9	31	
	TG12M4 -105			12		20	28.9	34	
C6	AC6- TG 6M -120		120	6	120	12	22.3	21	36 or longer
	-165						27.0		
	TG 8M -120			8		14	24.3	25	
	-165						29.0		
	TG10M -120	10		16		26.3	31		
	-165					31.0			
TG12M4 -120	12	20	30.3	34					

◆ NOTES ◆ 1. For shrink fitting, please use the ThermoGrip heating device (see ThermoGrip catalog).  
2. We also offer a variety of other straight shank shrink fit holders.

## Extension

Extend adapter length.

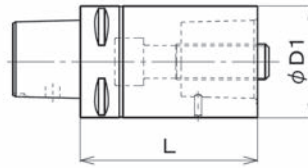

● Form explanation

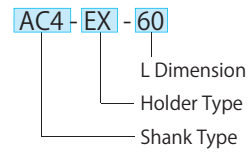

SIZE		CODE			wrench	Tightening torque (Nm)
Machine-Side	Tool-Side		φ D1	L		
C4	C4	AC4 - EX - 60	40	60	H 8	55
C5	C5	AC5 - EX - 80	50	80	H10	95
C6	C6	AC6 - EX - 100	63	100	H14	170
		-140		140		

## Reduction

Converts interfaces and reduces interference.

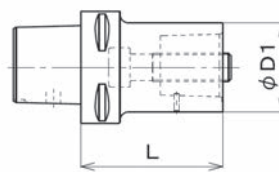

● Form explanation

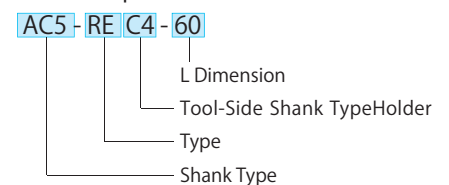

SIZE		CODE			wrench	Tightening torque (Nm)
Machine-Side	Tool-Side		φ D1	L		
C5	C4	AC5 - REC4 - 60	40	60	H 8	55
C6	C5	AC6 - REC5 - 80	50	80	H10	95

## Adapter for Presetter

The adapter to attach BT shank to a presetter.

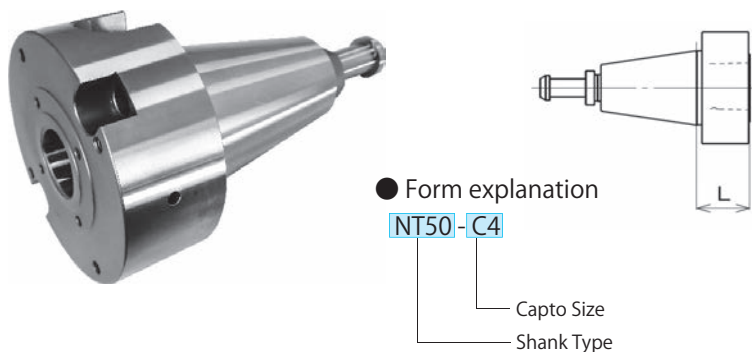

Code Size	Dimension
	L
NT50-C3	50
NT50-C4	
NT50-C5	
NT50-C6	



Please use NIHON I.D SYSTEM's TP-400 or TP-300 type presetter.

- Please use with hydraulic clamp (option).
- Tool length adjustment bolt for tool pre-setting is available. (option)

## Master gage for presetter

TP-400(QUALITY TYPE)

TP-300(STANDARD TYPE)

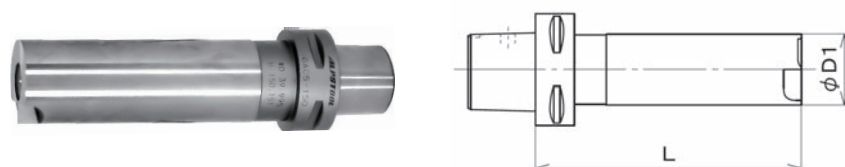

SIZE	CODE	Dimension	
		L	φ D1
C3	GAC3-150	150	40
C4	GAC4-150		
C5	GAC5-150		
C6	GAC6-150		
C8	GAC8-150		

## BT Shank QC Holder

The adapter for quick change from BT shank to CAPTO.  
The adapter to attach BT shank to a presetter.

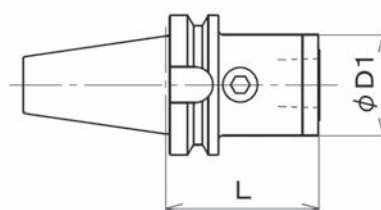

Taper Size	CODE	CAPTO SIZE	Dimension	
			φ D1	L1
BT30	BT30- AC3 - 75	C3	50	75
	BT40- AC3 - 80	C3	50	80
BT40	AC4 - 90	C4	55	90
	AC5 -105	C5	72	105
BT50	BT50- AC3 - 95	C3	50	95
	AC4 -100	C4	55	100
	AC5 -110	C5	72	110
	AC6 -127	C6	100	127
	AC8 -155	C8	133	155

● Form explanation

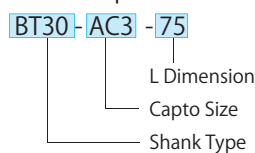

## Sensor Holder

The holder for mounting Renishaw touch sensors and other sensors from various manufacturers. Please contact us.



## Test Bar

Coaxiality can be checked.



SIZE	CODE	Dimension	
		$\phi$ D	L
C4	AC4-MAS-160	25	160
C5	AC5-MAS-180	30	180
C6	AC6-MAS-220	35	220

● Form explanation

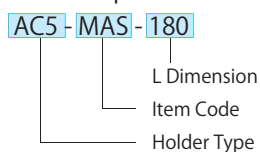

## Tool Clamp Base

By moving the position of the base, the tool can also be used facing upwards.

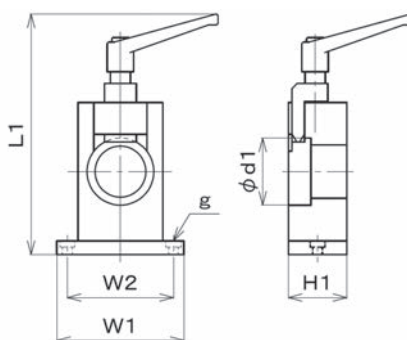

● Form explanation

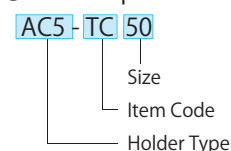

SIZE	CODE	Dimension					
		$\phi$ d1	W1	W2	H1	L1	g
C3	AC3-TC32	32	120	100	45	206.08	M8
C4	AC4-TC40	40			50		
C5	AC5-TC50	50			55	226.08	
C6	AC6-TC63	63					

# Short type Adapter

Short projection allows for efficient use of the tooling area.  
Ideal for Live tools.

## Collet Holder

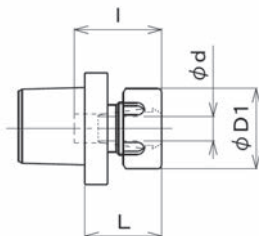

● Form explanation

AC5 S - ECH 13 F - 30

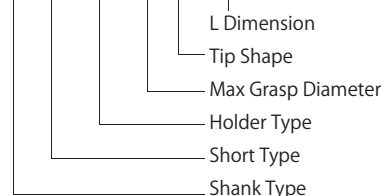

SIZE	CODE	Collet Chuck Code	Dimension				Wrench
			$\varphi d$	$\varphi D1$	L	I	
C3	AC3S- ECH7F -22	AR11-d	0.5~7	23	22	25	FK-3
	ECH10F -30	AR16-d	1~10	30	30	33	FK-4
C4	AC4S- ECH10F -28	AR16-d	1~10	30	28	34	FK-4
	ECH13F -31	AR20-d	1~13	35	31	36	FK-5
	ECH16F -35	AR25-d	1~16	42	35	41	FK-6
C5	AC5S- ECH13F -30	AR20-d	1~13	35	30	37	FK-5
	ECH16F -34	AR25-d	1~16	42	34	41	FK-6
	ECH20F -39	AR32-d	3~20	50	39	46	FK-7
C6	AC6S- ECH20F -38	AR32-d	3~20	50	38	46	FK-7

- ◆ NOTES ◆
1. It is compatible only with segment clamps. (It cannot be used with center bolt clamp holders)
  2. It is not compatible with ATC.
  3. Please order a spanner separately.

## Side Lock Adapter

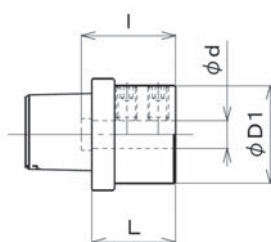

● Form explanation

AC5 S - SLA 16 - 34

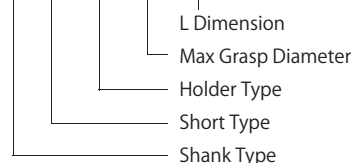

SIZE	CODE	Dimension			
		$\varphi d$	$\varphi D1$	L	I
C3	AC3S- SLA8 -24	8	28	24	27
	SLA10 -24	10		25	31
C4	AC4S- SLA10 -25	10	32	29	35
	SLA12 -29	12		36	41
C5	AC5S- SLA12 -29	12	36	34	41
	SLA16 -34	16		34	41

- ◆ NOTES ◆
1. It is compatible only with segment clamps. (It cannot be used with center bolt clamp holders)
  2. It is not compatible with ATC.



# Short type Adapter

Short projection allows for efficient use of the tooling area.  
Ideal for Live tools.

## Face Mill Adapter

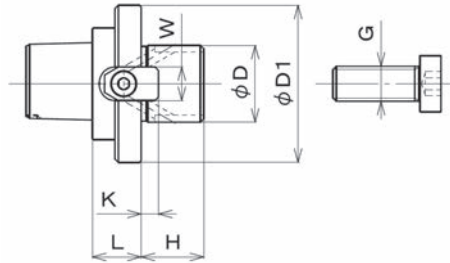
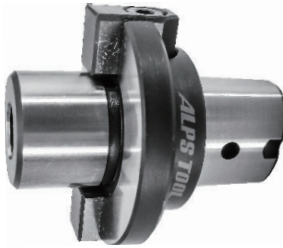

● Form explanation

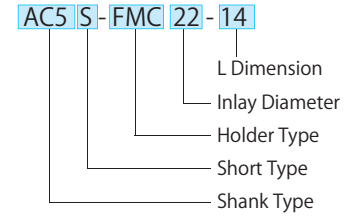

SIZE	CODE	Dimension						
		$\phi D$	$\phi D1$	L	H	K	W	G
C3	AC3S- FMC22 -14	22	45	14	18	5	10	M10
C4	AC4S- FMC22 -14							
C5	AC5S- FMC22 -14							

- ◆ NOTES ◆
1. It is compatible only with segment clamps. (It cannot be used with center bolt clamp holders)
  2. It is not compatible with ATC.

## Screw-in Adapter

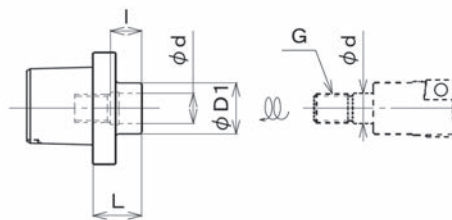

● Form explanation

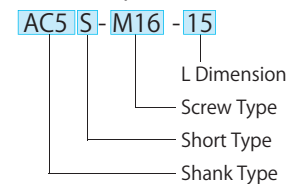

SIZE	CODE	Dimension				
		G	$\phi d$	$\phi D1$	L	I
C3	AC3S- M8 -14	M8	8.5	14.5	14	9
	M10 -15	M10	10.5	18	15	
	M12 -18	M12	12.5	23	18	
C4	AC4S- M10 -12	M10	10.5	18	12	
	M12 -15	M12	12.5	23	15	
	M16 -25	M16	17	28	25	
C5	AC5S- M12 -14	M12	12.5	23	14	
	M16 -15	M16	17	28	15	

- ◆ NOTES ◆
1. It is compatible only with segment clamps. (It cannot be used with center bolt clamp holders)
  2. It is not compatible with ATC.

## Square Shank Clamping Unit

ALPS CAPTO can be immediately installed in the wedge-type square tool groove.



Cam type

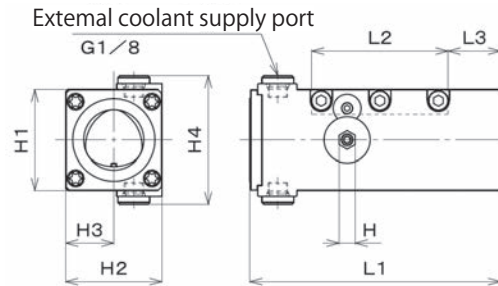

SIZE	CODE	Dimension							
		H1 Mounting Width	H2	H3	H4	L1	L2	L3	H
C3	AC3-XXAA133-3K000R/L	40	38	19	62	95	16.5	16.5	8
C4	AC4-XXAA133-4K000R/L	50	48	24	64	125	68	28	10
C5	AC5-XXAA133-5K000R/L	64	64	32	68	145	82	25.5	12

- ◆ NOTES ◆  
1. The model number ends with "L" for the left hand and "R" for the right hand.  
Example: AC4-XXAA133-4K000L...left hand, AC4-XXAA133-4K000R...right hand.

## Round Shank Clamping Unit

ALPS CAPTO can be immediately installed in the round shank holder.

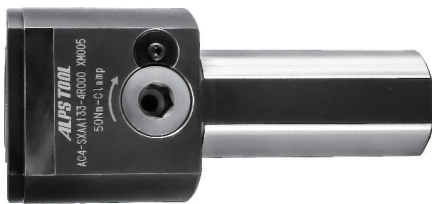

Cam type

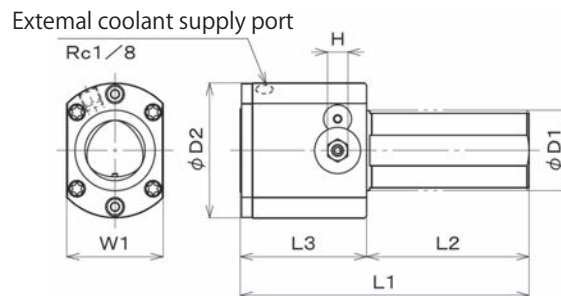

SIZE	CODE	Dimension						
		φ D1 Mounting Width	φ D2	W1	L1	L2	L3	H
C3	AC3-XXAA133-3R000	32	54	38	133	80	53	8
C4	AC4-XXAA133-4R000	40	67	48	144	81	63	10

- ◆ NOTES ◆  
1. D1 shank has four flat surfaces.  
2. If using internal coolant, please pipe it.  
3. Special mounting diameters are available.



Pull-screw type

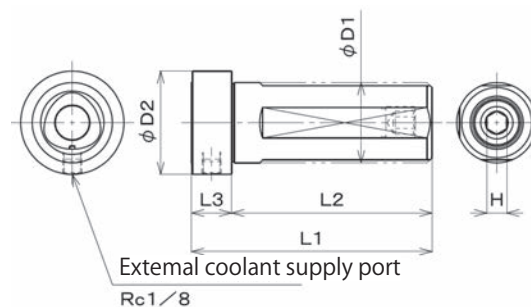

SIZE	CODE	Dimension					
		φ D1 Mounting Width	φ D2	L1	L2	L3	H
C3	AC3-XXAA133-3D000	32	45.5	98	80	18	8
C4	AC4-XXAA133-4D000	40	51.5	120	100	20	10
C5	AC5-XXAA133-5D000	50	61.5	144	120	24	12

- ◆ NOTES ◆  
1. D1 shank has four flat surfaces.  
2. If using internal coolant, please pipe it.  
3. Special mounting diameters are available.

# **ALPS TOOL**

**That's the way!**

<https://atc.sub.jp/en/>



**ALPS TOOL CO.,LTD.**

**HQ, Factory 1** 10070 Sakaki, Sakaki-machi, Hanishina-gun, Nagano-ken, 389-0601 Japan

**Factory 2** 10030 Sakaki, Sakaki-machi, Hanishina-gun, Nagano-ken, 389-0601 Japan

**Factory 3** 102-8 Nakanojo, Sakaki-machi, Hanishina-gun, Nagano-ken, 389-0602 Japan

TEL +81-268-82-2511 FAX +81-268-82-7368

TEL +81-268-82-4811 FAX +81-268-82-8741

TEL +81-268-82-7911 FAX +81-268-82-7919

**ALPS TOOL(Dalian)CO.,LTD.**

**Dalian Factory** No.7 Yuexiang Street, Wanli Sub-district, Dalian Economic and Technical Development Zone, Dalian Liaoning China

TEL +86-411-87935969 FAX +86-411-87935255

**ALPS TOOL(THAILAND)CO.,LTD.**

**Ayutthaya Factory** Hi-Tech Industrial Estate,144 Moo 1, Tambol Banlen, Amphur Bang Pa-In, Ayutthaya 13160 Thailand

TEL +66-35-314-071 FAX +66-35-314-075

**Suranaree Factory** 567 Moo6 Tambol Nongraviang Amphur Muang Nakhon Ratchasima 30000 Thailand

TEL +66-44-009-838 FAX +66-44-009-839

**ALPS TOOL USA, INC.** 5420 Newport Drive, Unit #51 Rolling Meadows, IL 60008 USA

TEL +1-847-342-0300 FAX +1-847-342-6355

**ALPS TOOL Europe GmbH** Vogelsangstr. 8, 73760 Ostfildern GERMANY

TEL +49-711-34801-139 FAX +49-711-34801-140